

CONSTRUCTION SPECIFICATIONS

Medina CDV23-0125 Amended Area

East Medina County Special Utility District

18313 FM 471 South

Devine, TX 78016



Prepared By:

RESPEC, LLC

1201 Fiorella St. Suite A

Castroville, TX 78009

June 8, 2026



RESPEC

Special Conditions

San Antonio Water System (SAWS) Construction Specifications

SAWS	812	Water Main Installation
SAWS	822	Customer's Water Yard Pipe
SAWS	824	Water Service Supply Lines Service Relays
SAWS	828	Gate Valves
SAWS	836	Grey Iron and Ductile-Iron Fittings
SAWS	839	Anchorage Thrust Blocking and Joint Restraint
SAWS	844	Temporary and Permanent Blow-off Assemblies
SAWS	846	Air Release Assemblies

San Antonio Water System (SAWS) Construction Specifications

MATERIAL	10-10	Gray-Iron and Ductile Iron Fittings
MATERIAL	21-02	Resilient-Seated Gate and Tapping Valves for Water Supply Service
MATERIAL	29-01	Air Release, Vacuum, & Combination Air Valves for Water Service
MATERIAL	95-10	Pipe Joint Restraint Systems

Special Specifications

- Division 33 Utilities
 - 33111 PVC Water Main SDR21
 - 33120 Small Diameter Pipe and Fittings
 - 33121 Small Diameter Water Tie-Ins

SPECIAL CONDITIONS FOR SPECIFICATIONS

PART I – GENERAL

1.01 SPECIAL CONDITIONS TO SPECIFICATIONS

- A. Technical specifications for this project are those of the Texas Department of Transportation, San Antonio Water System, and City of San Antonio to meet technical and construction standards only. Any reference to Texas Department of Transportation, San Antonio Water System or City of San Antonio for permission or approval is meant to apply to East Medina County Special Utility District as the project owner.
- B. Water service relays shall be furnished and installed per detail on plans. Yard piping shall consist of the same material as relay piping.
- C. Permanent blow-off valves shall be furnished and installed per detail on plans. All blow-off valves shall be painted black.
- D. All valves shall be open left.

END OF SECTION

San Antonio Water System Standard Specifications for Construction

ITEM NO. 812

Water Main Installation

812.1 DESCRIPTION: This item shall consist of water main installation in accordance with these specifications and as directed by the Engineer.

812.2 REFERENCE STANDARDS: Reference standards cited in this Specification Item No. 812 refer to the current reference standard published at the time of the latest logged revision date.

1. San Antonio Water System (SAWS):
 - a. Specifications for Water and Sanitary Sewer Construction
 - b. SAWS Materials Specifications
2. City Of San Antonio (COSA) Standard Specifications for Construction
3. Texas Commission of Environmental Quality (TCEQ) Chapter 290 Public Water Supply
4. American National Standards Institute (ANSI)/American Water Works Association (AWWA)
 - a. ANSI A 21.11/AWWA C111 - Standard for Rubber-Gasket Joints for Ductile-Iron Pressure Pipe and Fittings.
 - b. ANSI/NSF Standard 61 - Drinking Water System - Health Components.
 - c. ANSI/AWWA C151/A21.51—Ductile-Iron Pipe, Centrifugally Cast.
 - d. ANSI/AWWA C515—Reduced-Wall, Resilient-Seated Gate Valves for Water Supply Service (5.5 lb) Rammon and a 305 mm (12 in.) Drop.
 - e. ANSI/AWWA C105/A21.5—Polyethylene Encasement for Ductile-Iron
 - f. Pipe Systems.
 - g. ANSI/AWWA C111/A21.11—Rubber-Gasket Joints for Ductile-Iron Pressure Pipe and Fittings.
 - h. ANSI/AWWA C150/A21.50—Thickness Design of Ductile-Iron Pipe.
 - i. ANSI/AWWA C500—Metal-Seated Gate Valves for Water Supply Service.
 - j. ANSI/AWWA C509—Resilient-Seated Gate Valves for Water Supply Service.
 - k. ANSI/AWWA C651—Disinfecting Water Mains.
5. American Society for Testing and Materials (ASTM) International:
 - a. ASTM A 36 - Standard Specification for Carbon Structural Steel.
 - b. ASTM A 536 - Standard Specification for Ductile Iron Castings.
 - c. ASTM A 126 - Standard Specification for Gray Iron Castings for Valves, Flanges, and Pipe Fittings.
 - d. ASTM B 21 - Standard Specification for Naval Brass Rod, Bar, and Shapes.
 - e. ASTM B 98 - Standard Specification for Copper-Silicon Alloy Rod, Bar, and Shapes.

San Antonio Water System Standard Specifications for Construction

- f. ASTM B 301 - Standard Specification for Free-Cutting Copper Rod and Bar.
 - g. ASTM B 584 - Standard Specification for Copper Alloy Sand Casting for General Application.
 - h. ASTM E 165 - Standard Test Method for Liquid Penetrant Examination.
 - i. ASTM E 709 - Standard Guide for Magnetic Particle Examination.
 - j. ASTM F 1674 - Standard Test Method for Joint Restraint Products for Use with PVC Pipe.
 - k. ASTM D2241, “Poly(Vinyl Chloride) (PVC) Pressure-Rated Pipe (SDR PR Series)”
6. American Water Works Association (AWWA)
- a. AWWA C 206 - Standard for Field Welding of Steel Water Pipe.
 - b. AWWA C 207 - Standard for Steel Pipe Flanges for Waterworks Service - Sizes 4 Inches through 144 Inches.
 - c. AWWA C605, “Underground Installation of Polyvinyl Chloride (PVC) Pressure Pipe and Fittings for Water
 - d. AWWA C651-05 Disinfecting Water Mains
 - e. AWWA C900, “Polyvinyl Chloride (PVC) Pressure Pipe and Fabricated Fittings, 4 in. through 60in. (100 mm through mm) for Water Distribution”
 - f. AWWA C907, “Polyvinyl Chloride (PVC) Pressure Fittings for Water —4 in. through 8 In (100 mm Through 200 mm)
 - g. AWWA Manual M27, External Corrosion: Introduction to Chemistry and Control
 - h. AWWA M28 Rehabilitation of Water MainsAWWA Manual M41— Ductile-Iron Pipe and Fittings.
 - i. AWWA Manual M17, Installation, Field Testing, and Maintenance of Fire Hydrants.
7. International Organization of Standardization (ISO)
- a. ISO9001

812.3 SUBMITTALS: All submittals shall be in accordance with most recent version of SAWS’s General Conditions requirements. Submit the following prior to performing any work.

- 1. Certifications:
 - a. Per General Conditions section 5.12.2 all Contractor submittals for all pipe and other products or materials furnished under this specification shall be marked as reviewed and approved by Contractor for compliance with Contract Documents and the referenced standards.
 - b. The Manufacturer shall provide ISO 9001 Certificate by a third party.
 - c. Submit written verification that the pipe Manufacturer has been manufacturing pipe per required ASTM with similar design pressure and size as this Project.
 - d. Submit written verification from the pipe Manufacturer demonstrating compliance with the production and delivery schedule of the pipe as

San Antonio Water System Standard Specifications for Construction

- indicated in the Contractor's schedule.
- e. Submit written verification from mechanical fitting Manufacturer that fittings are compatible with proposed pipe and meets the requirements of this section.
2. Contractor shall submit Manufacturer's product data, installation recommendations, allowable deflection, shop drawings, and certifications.
 3. Shop Drawings:
 - a. Catalog Data Sheets for all materials confirming pipe, fittings, and other materials conform to requirements of this specification.
 - b. Pipe Supplier Information. Submit company name, contact name, and contact number.
 - c. Details of all piping systems components confirming that the pipe and fittings conform to the specified requirements.
 - d. The Contractor shall submit shop drawings of pipe, fittings, gaskets, hardware, flanges, appurtenances, special details sufficient to demonstrate compliance with these Specifications and applicable pipe installation Specification.
 - e. Fabrication drawings showing:
 - 1) Wall thickness.
 - 2) Pipe length.
 - 3) Pipe joint (i.e. mechanical, flanged. fused)
 4. Testing Plan: Submit at least prior to start of construction and at minimum, include the following:
 - a. Testing dates.
 - b. Piping systems and section(s) to be tested.
 - c. Method of isolation. Method of isolation to be approved by SAWS Inspector.
Method of conveying water from source to system being tested.
 - d. Hydrostatic leak testing.
 - i. Submit a hydrostatic leak testing plan which includes equipment (pump, water meter, pressure regulating valve, pressure gauges, etc.), water handling procedures (supply and disposal), sequence and schedule by test section, and pressure test data
 - ii. Certifications of Calibration: Approved testing laboratory certificate if pressure gauge for hydrostatic test has been previously used. If pressure gauge is new, no certificate is required.
 5. Testing Reports:
 - a. Furnish affidavit certified that all pipe meet the provisions of the specification and has been tested and submit reports in accordance with the applicable ASTMs and AWWA Standards. Reports to include the following:

San Antonio Water System Standard Specifications for Construction

- i. Hydrostatic proof test reports.
 - ii. Sustained pressure test reports.
 - iii. Burst strength test reports.
 - iv. Stress Regression Testing
 - v. Additional reports may be requested by SAWS Inspector
6. Fusion information as required by Specification Item No. 815 HDPE Installation.
7. The Contractor shall also submit details of welding/fusing procedures and equipment to be used.
8. Detail drawings indicating type, number, and other pertinent details of the slings and/or other methods proposed for pipe support and handling during manufacturing, transport, and installation. All pipe handling equipment and methods shall be acceptable to Owner.
9. Pipe Manufacturer's Written Quality Assurance/Quality Control Program.
10. Field Service Representative Resume.

812.4 MATERIALS: The materials for water main installation shall conform to the specifications contained within the latest revision of SAWS Material Specifications:

1. Material Specification Item No. 113-03: Specifications Ductile-Iron Restrained Joint Fittings for Use on Ductile Iron and Poly-Vinyl Chloride Pipe
2. Material Specification Item No. 05-11: Specifications Ductile Iron Pipe
3. Material Specification Item No. 05-12: Specifications for C-900 Polyvinyl Chloride (PVC) Pressure Pipe, 4-inch Through 12-Inch
4. Material Specification Item No. 05-13: Specifications for C909 Oriented Polyvinyl Chloride (PVC) Pressure Pipe, 4-Inch Through 12-Inch
5. Material Specification Item No. 05-20: Specifications for Prestressed Concrete Pressure Pipe Steel Cylinder Type
6. Material Specification Item No. 05-30: Specifications for Steel Water Pipe
Specification Item No. 815: Specifications for High Density Polyethylene Pipe
7. The pressure rating for pipe materials apply to any work performed in SAWS Pressure Zones. Minimum pressure rating for all pipes shall be 235 psi, or as identified in plans and bid documents.
8. PVC water pipe shall be blue in color. **White PVC pipe is not permitted.**
9. PVC Water pipe sizes greater than 24" shall not be allowed. PVC pipe markings shall include:
 - a. Manufacturer's name or trademark;
 - b. Standard to which it conforms;
 - c. Pipe size;
 - d. Material designation code;
 - e. Pressure rating;
 - f. SDR number or schedule number;

San Antonio Water System Standard Specifications for Construction

- g. Potable water laboratory seal or mark attesting to suitability for potable water;
- h. A certifier's mark may be added; and
- i. Manufactured date (installation shall not exceed one year from this date)

812.5 CONSTRUCTION:

1. The Contractor shall start his work near a tie-in or point designated by the Inspector.
2. Pipe shall be laid with bell ends facing in the direction of pipe laying, unless otherwise authorized or directed by the Inspector.
3. All valves and fire hydrants must be installed as soon as pipe laying reaches their established location.
4. All pipe shall be installed to the required lines and grades with fittings, valves, and hydrants placed at the required locations.
5. Spigots shall be centered in bells or collars, all valves and hydrant stems shall be set plumb, and fire hydrant nozzles shall face as per SAWS standard details..
6. No valve or other control on the existing system shall be operated for any purpose by the Contractor unless a representative of SAWS is present.
7. New water mains crossing any other utility shall have a minimum of 5 feet of cover over the top of the pipe, unless otherwise waived or modified by the Engineer.
8. Excavation around other utilities shall be done by hand for at least 12 inches all around.
9. Any remedial measures for damages will be at Contractors expense.
10. Any damage to the protective wrap on gas lines or electrodes shall be reported immediately to the CPS Energy, phone (210) 353-4357.
11. Any damage to other utilities shall be reported to their proper governing entity.
12. In any case of utility damage, the Contractor shall also promptly notify the Inspector.
13. Any remedial measures for damages will be at Contractor's expense.
14. New waterline installation and separation shall comply with TCEQ Chapter 290; Subchapter D – Rules and Regulations for Public Drinking Water criteria for the location and installation of waterlines. See Drawings series DD-812.
15. All separation distances shall be measured from the outside surfaces of each of the respective pieces.
16. The bedding and backfill of the existing wastewater mains or laterals shall not be disturbed.
17. All water mains shall have a minimum of 5 feet of cover from the proposed final finish ground/street/elevation unless otherwise adjusted by the Engineer.
18. Pipe grades shall be as required by the contract documents or as directed by the Engineer.
19. Precaution shall be taken to ensure that the pipe barrel has uniform contact with the cushion material for its full length except at couplings.
20. The couplings shall not be in contact with the original trench bottom prior to

San Antonio Water System Standard Specifications for Construction

- backfilling.
21. Cushion material shall be placed under the coupling and compacted by hand prior to backfilling so as to provide an even bearing surface under the coupling and pipe.
 22. Prior to placing pipe in a trench, the trench shall have been excavated to the proper depth as required in plans and Specification Item No. 804 "Excavation, Trenching, and Backfilling."
 23. Approved imported materials or Engineer-approved native materials, as per Specification Item No. 804 "Excavation, Trenching, and Backfilling," shall be smoothly worked across the entire width of the trench bottom to provide a supporting cushion.
 24. When either the Inspector or Engineer note that the material at the bottom of a trench is unstable or unsuitable, it shall be removed and replaced with approved material which may be properly compacted in place to support the pipe. See Specification Item No. 804 "Excavation, Trenching, and Backfilling,"
 25. If required the Contractor shall also construct a foundation for the pipe consisting of piling, concrete beams, or other supports in accordance with contract documents prepared by the Engineer.
 26. Proper implements, tools, and facilities satisfactory to the Inspector shall be provided and used by the Contractor for the safe and convenient completion of work.
 27. All pipe, fittings, valves, and hydrants shall be carefully lowered into the trench piece by piece, by means of a derrick, ropes, or other suitable tools or equipment in such a manner as to prevent damage to water main materials and protective coatings, polywrap sleeving, and linings.
 28. Under no circumstances shall water main materials, pipes, fittings, etc., be dropped or dumped into the trench.
 29. Extreme care shall be taken to avoid damaging polywrap films. No chains or slings shall be allowed unless the entire sling is wrapped with a protective nylon web sock.
 30. To prevent pipe damage, proper implements, tools, and equipment should be used for placement of the pipe in the trench; pipe and/or accessories should never be dropped into the trench.
 31. After placing a length of pipe in the trench, the jointed end shall be centered on the pipe already in place, forced into place, brought to correct line and grade, and completed in accordance with requirements.
 32. The pipe shall be secured in place with approved initial backfill material tamped around it.
 33. Precautions shall be taken to prevent dirt or other foreign matter from entering the joint space.
 - a. Under adverse trenching conditions, work stoppage for more than 24 hours and/or as otherwise required by the Inspector, a manufactured water tight cap/plug is to be used at each end to prevent any foreign type material entering the pipe and to make the pipe watertight.

San Antonio Water System Standard Specifications for Construction

- b. This provision shall apply during all periods when pipe laying is not in progress.
 - c. Should water enter the trench, the seal shall remain in place until the trench is pumped completely dry.
 - d. The Contractor shall provide all plugs and caps of the various sizes required.
 - e. The cap/plug shall be left in place until the pipe is connected to an adjacent pipe.
 - f. The interior of each pipe shall be inspected for foreign material or defects, and the pipe shall be cleaned or rejected if any defects are found.
34. Deviations in Alignment
- a. Wherever obstructions not shown in the contract documents, to include changes in depth and/or alignment, are encountered during the progress of the work and interfere to an extent that an alteration in the plan is required, the Engineer shall have the authority to change the contract documents and direct a deviation from the alignment or to arrange with the owners of the structures for the removal, relocation, or reconstruction of the obstructions.
 - b. Any deviation from the alignment shall be accomplished by the use of appropriate bends unless such requirement is specifically waived by the Engineer.
 - c. These deviations shall clearly and accurately be reflected in the Contractor's submittal of their redline drawings for permanent recording purposes.
 - d. Whenever it is necessary to deflect pipe from a straight line, the deflection shall be as directed by the Engineer.
 - e. In no case shall the amounts shown in Table 1, Maximum Deflections of Ductile Iron Pipe, or Table 2, Maximum Deflections of Concrete Steel Cylinder Pipe, or as per manufacture's recommendation for pipe deflection be exceeded.
 - f. If deflection is exceeded, bends must be incorporated.
 - g. Deflection of PVC (C-900, and C-909) shall be limited to 1 degree of the manufacturers recommended deflection as noted in specification 818 Water Pipe Installation PVC (C-900, and C-909) Pipe 4 inch to 24 in Pipe
 - i. Changes in direction of PVC pipe shall only be use of fittings or by deflecting straight pipe sections at joints.
 - ii. Longitudinal bending of pipe is not allowed
 - iii. Deflection of pipe fittings is not allowed
 - iv. Deflection of straight pipe sections shall not exceed 1 degree at each joint (even if joint restraint devices are installed), which corresponds to the following in pipe alignment:
 - 1) Length of pipe, feet offset, inches allowable radius of cuvature, feet
204 maxium, feet 1,1146 minimum

San Antonio Water System Standard Specifications for Construction

TABLE 1					
MAXIMUM DEFLECTIONS OF DUCTILE-IRON					
Nominal Pipe Diameter	Maximum Deflection Angle	Maximum Deflection In Inches		Approximate Radius Of Curve In Inches	
		18 Ft.	20 Ft.	18 Ft.	20 Ft.
6"	4°25'	16.7	18.5	234	260
8"	3°51'	14.6	16.2	268	297
10"	3°42'	14.0	15.5	279	310
12"	3°08'	11.9	13.2	327	363
16"	2°21'	8.8	9.7	440	488
20"	1°55'	7.2	8.0	540	600
24"	1°35'	6.0	6.7	648	720

San Antonio Water System Standard Specifications for Construction

TABLE 2					
MAXIMUM DEFLECTIONS OF CONCRETE STEEL CYLINDER					
Nominal Pipe Diameter	Maximum Deflection Angle	Maximum Deflection In Inches		Approximate Radius Of Curve In Inches	
		16 Ft.	20 Ft.	16 Ft.	20 Ft.
16"	2°20'	--	9.8	--	500
20"	1°52'	--	7.8	--	600
24"	1°34'	--	6.6	--	750
30"	1°16'	--	5.3	--	900
36"	1°02'	--	4.3	--	1100
42"	0°54'	--	3.8	--	1300
48"	0°47'	2.6	--	1170	--
54"	0°44'	2.5	----	1237	--
60"	0°54'	3.0		1024	-

35. Cutting Pipe:
- a. The cutting of pipe for inserting valves, fittings, or closure pieces shall be accomplished in a neat and workmanlike manner so as to produce a smooth end at right angles to the axis of the pipe.
 - b. The recommendations of the pipe manufacturer shall be strictly followed by the Contractor.
 - c. Only qualified and experienced workmen shall be allowed to cut pipe and, under no circumstances, shall a workman not equipped with proper safety goggles, helmet and all other required safety attire be permitted to engage in this work.
 - d. All cuts made on ductile-iron pipe shall be done with a power saw.
 - i. The cuts shall be made at right angles to the pipe axis and shall

San Antonio Water System Standard Specifications for Construction

- ii. be smooth.
 - iii. The edges of the cut shall be finished smoothly with a hand or machine tool to remove all rough edges.
 - iv. The outside edge of pipe should be finished with a small taper at an angle of about 30 degrees.
 - v. Solid sleeves or cast couplings shall be allowed on precast/prefab vaults only.
 - vi. All fire line services shall be installed with full joints of pipe.
 - e. **Tapping of CSC pipe is only allowed by CSC Manufacturer of pipe brand being tapped or CSC Manufacturer approved by SAWS. See Specification Item No. 820 Concrete Steel Cylinder Pipe Installation.**
 - f. To facilitate future repair work on water mains, no sections less than 3 feet in length between fittings shall be allowed.
 - g. Asbestos Cement (AC): No field cutting, breaking, or crushing will be allowed on AC pipe.
 - i. Repairs to AC pipe shall be accomplished by removing one full joint of AC pipe and replacing with appropriate PVC, Ductile Iron pipe, CSC, or HDPE pipe and fittings.
 - ii. All work associated with removing and disposing of AC pipe shall conform to the provisions of Item No. 3000, "Handling of Asbestos Cement Pipe."
36. Joint Assembly:
- b. Rubber Gasketed Joints: The installation of pipe and the assembly of rubber gasketed joints for ductile iron pipe, PVC, HDPE, CSC pipe shall conform to the pipe manufacturer's assembly instructions.
 - c. The method of inserting spigot ends of pipe in bells or collars known as "stabbing" shall not be permitted with pipe larger than 6 inches in size.
 - d. Spigot ends of pipe larger than 6 inches in size must be properly inserted in the joint by means of suitable pushing/pulling devices or an approved manufacture's method.
 - e. PVC spigot ends shall be pushed in until the lip of the bell is between the reference marks on the spigot end.
 - i. If the spigot is inserted beyond the insertion point, the pipe will have to be pulled out and reinserted.
 - ii. Pipe should be inspected to ensure pipe has not been damaged prior to reinsertion.
 - iii. Any damaged pipe shall be replaced at Contractors expense.
 - f. Mechanical couplings shall be assembled and installed according to the standards recommended by the manufacturer.
 - i. Prior to the installation of the mechanical coupling, the pipe ends shall be cleaned by wire brush or other acceptable method to provide a smooth bearing surface for the rubber compression gasket.
 - ii. The pipe shall be marked to align the end of the coupling which will center it over the joint.

San Antonio Water System Standard Specifications for Construction

- iii. After positioning, the nuts shall be drawn up finger tight.
 - iv. Uniform pressure on the gaskets shall be applied by tightening alternate bolts on the opposite side of the circle in incremental amounts.
 - v. Final tensioning shall be accomplished with a torque wrench and in a manner similar to the tightening procedure.
 - vi. Final torque check shall then be made prior to coating and wrapping the joint.
 - vii. Refer to manufacturer's recommendations for proper torque.
 - g. Restraint Joints shall be installed as shown on the contract documents or as directed by the Engineer.
 - a. Installation shall conform to the manufacturer's recommendation.
 - b. Refer to Specification Item No. 839 Anchorage/Thrust Blocking and Joint Restraints.
37. Abandonment/Removal of Existing Mains:
- a. The Contractor shall accomplish all cutting, capping, plugging, and blocking necessary to isolate existing mains retained in service from abandoned mains.
 - b. The open ends of abandoned mains and all other openings or holes in such mains occasioned by cutting or removal of outlets shall be blocked off by pressure forcing cement grout or concrete into and around the openings in sufficient quantity to provide a permanent substantially watertight seal.
 - c. Abandonment of existing water mains will be considered subsidiary to the work required, and no direct payment will be made.
 - d. Capping or plugging of main is preferred over grouting. For mains 12" and larger, under major thoroughfare or highways, grouting will be required.
 - e. When specified or shown otherwise in the contract documents, Contractor shall remove the main and all related appurtenances that are to be replaced, or will no longer be in service, and all effort to accomplish this requirement will be considered subsidiary to the work required, and no direct payment will be made.
 - f. Removed AC pipe shall be manifested and disposed of in accordance with Item No. 3000, "Handling Asbestos Cement Pipe."
- Valves abandoned in the execution of the work shall have the valve box and extension removed in its entirety and filled with flowable fill to within 12" inches of the surface.
- a. The remaining 12" inches shall be filled with required asphaltic pavement or top soil and sod and finished flush with the adjacent pavement or ground surface as required (N.S.P.I.).
- At no time during the project work shall any valves be covered or rendered inaccessible for operation due to any activities by the Contractor.
39. Any work during construction activities will be suspended until this requirement is met.
40. No claims for cost or schedule delays will be accepted.

San Antonio Water System Standard Specifications for Construction

812.6 MEASUREMENT:

1. Water main installed will be measured by the linear foot for each size and type as follows:
 - a. Measurements will be from the center line intersection of runs and branches of tees to the end of the valve of a dead end run.
 - b. Measurements will also be between the center line intersection of runs and branches of tees.
 - c. Where the branch is plugged for future connection, the measurement will include the entire laying length of the branch or branches of the fitting.
 - d. The measurement of each line of pipe of each size will be continuous and shall include the full laying lengths of all fittings and valves installed between the end of such line except that the laying length of reducers will be divided equally between the connected pipe sizes.
 - e. Lines leading to a tapping connection with an existing main will be measured to the center of the tapped main.

812.7 PAYMENT: Payment for water main installed will be made at the unit price bid per linear foot of pipe of the various sizes installed by the open cut method.

1. Such payment shall also include excavation, concrete encasement, pipe encasement, spacers, grout, selected embedment material, backfill, compaction, compaction testing, polyethylene sleeve, fittings, adapters, couplings, anchors, cathodic protection if required, tracer wire and detection tape if required, hauling and disposition of surplus excavated material, including all existing pipe, fittings, appurtenances to be abandoned or removed, installation of all weather surface, and other required testing as per Specification Item No. 804, "Excavation, Trenching, and Backfilling,"
2. Materials paid on site will be in accordance with Table 1 of Specification Item No. 100 Mobilization.

-End of Specification-

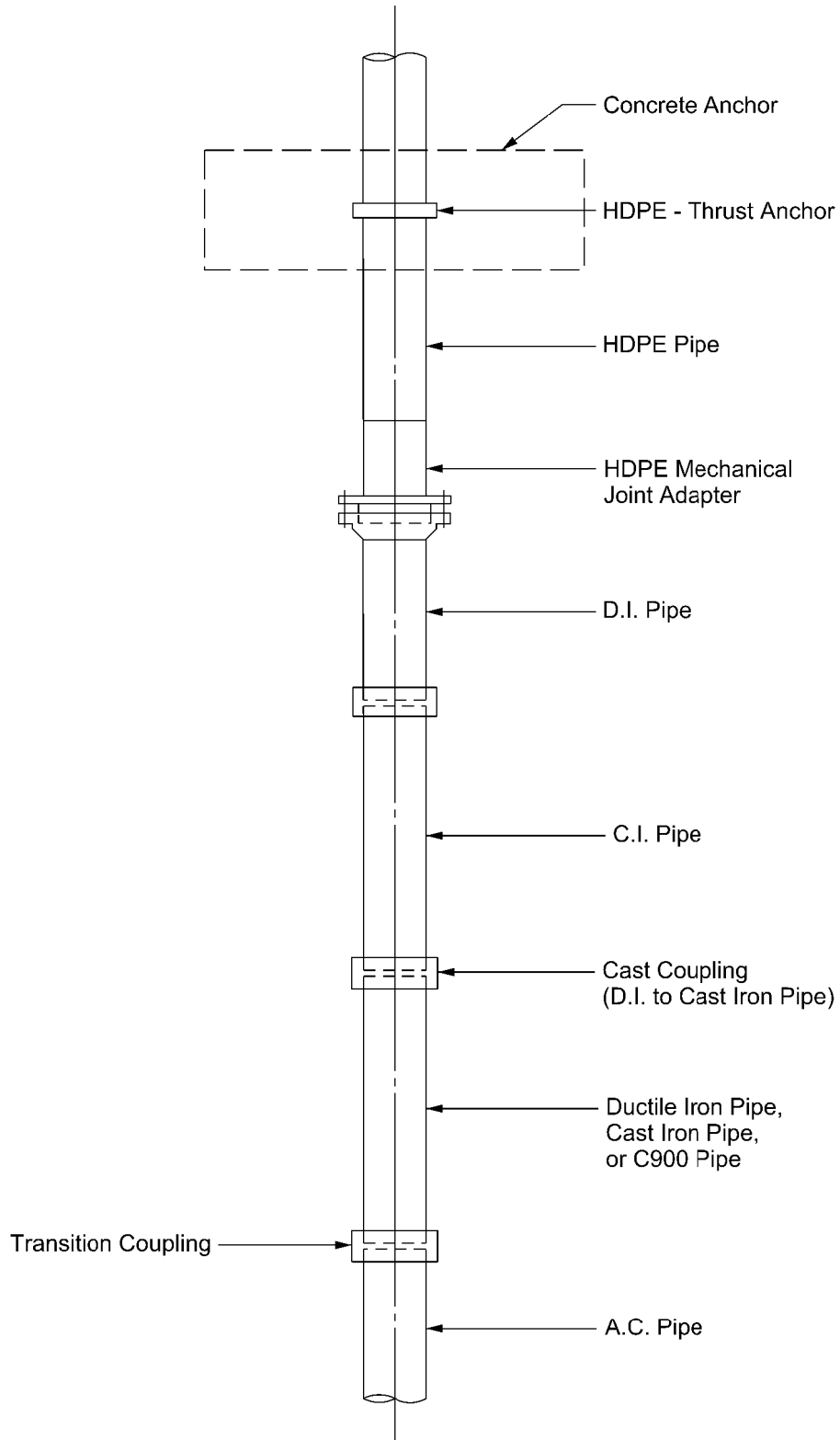

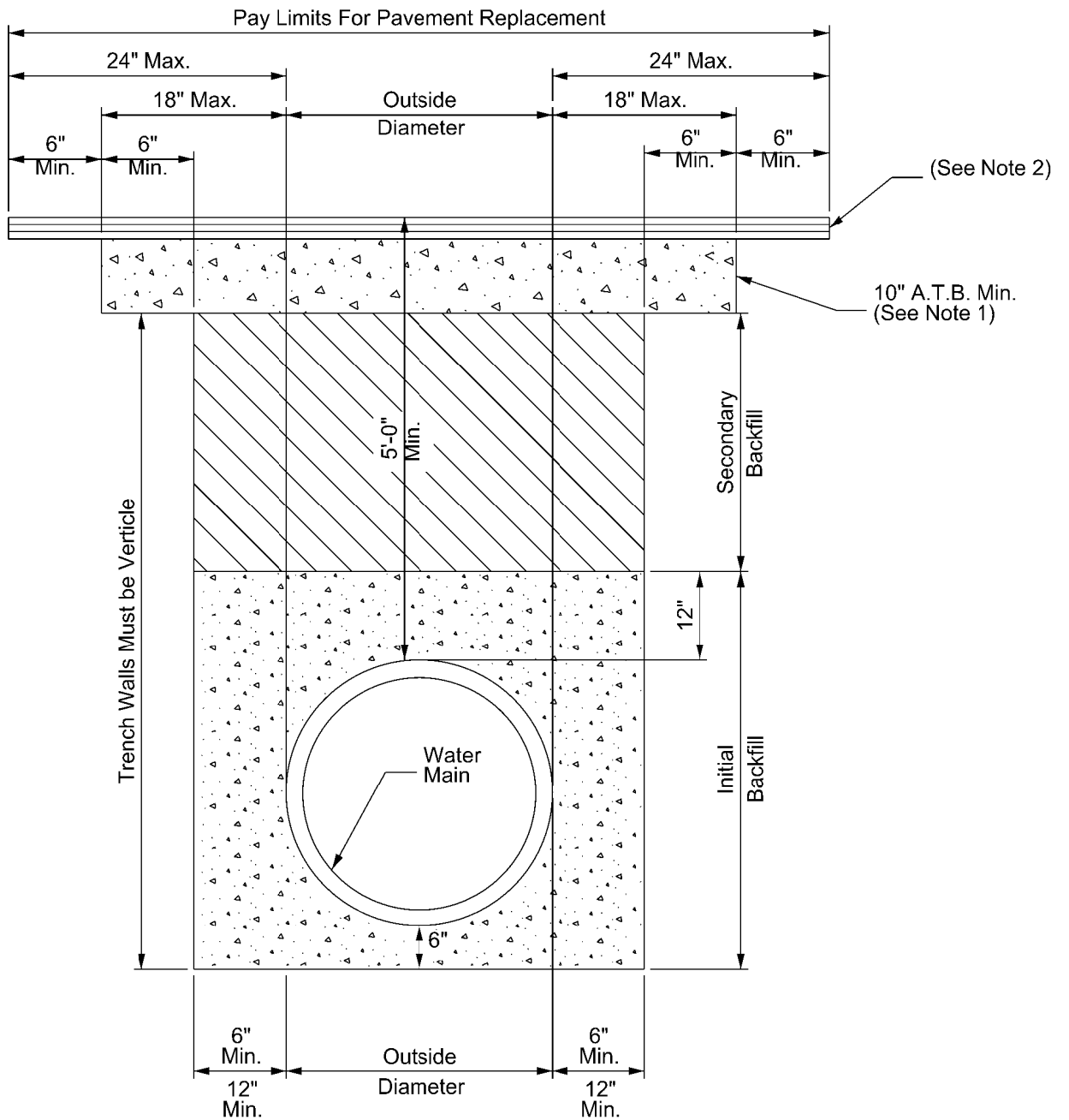

1. Asphalt Treated Base - As Specified COSA ROW - 10" Min. or Greater.

2. Replacement of Surface Layer Shall be of the Type and Thickness Base On Functional Classification.

- a. Min 2" HMAC Type "D" for Trench Repair in Local / Residential Streets.
- b. Min. 3" HMAC Type "C" for Trench Repair in Collector / Arterial Streets.

- Asphalt Treated Base (ATB)
- Hot Mix Asphalt Concrete (HMAC)

PROPERTY OF
SAN ANTONIO WATER SYSTEM
SAN ANTONIO, TEXAS

POTABLE AND RECYCLED
WATER MAIN DETAIL

APPROVED
MARCH 2008

REVISED
AUG 2019

DD-812-01

SHEET
2 OF 9

EXISTING / NEW WATER LINES CONSTRUCTED
LOCATION OF WATER LINES

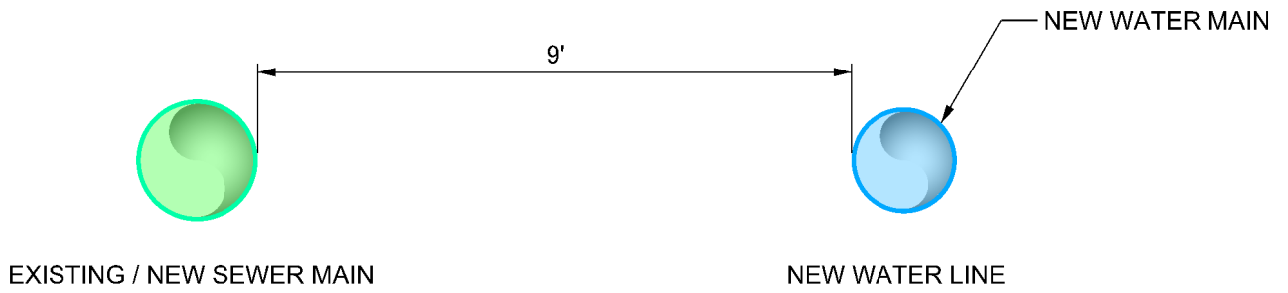

Where the nine foot separation distance can not be achieved, the following criteria shall apply: LOCATION OF WATER LINES - PARRALLEL LINE

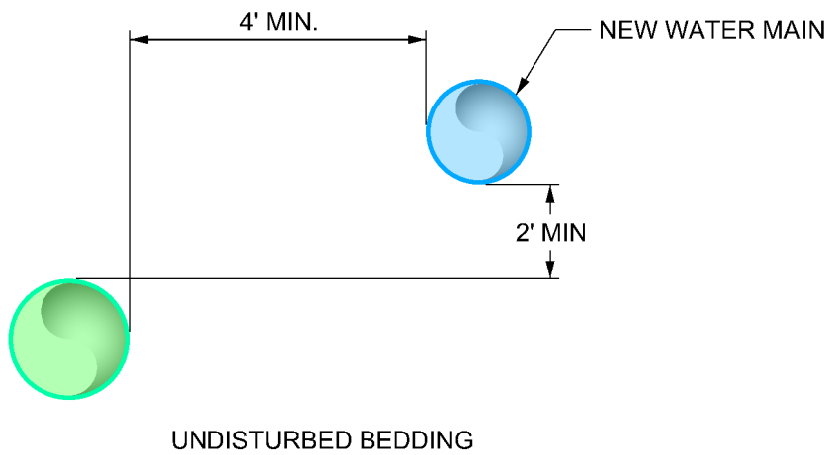

NEW WATER LINE CROSSES AN EXISTING NON-PRESSURE RATED WASTEWATER MAIN: NEW WATERLINE INSTALLATION - CROSSING LINES

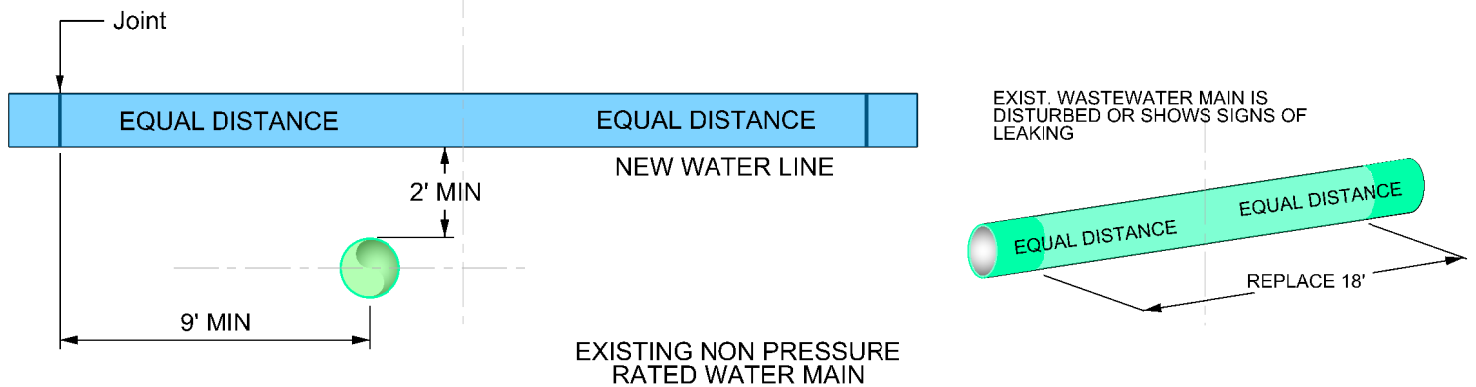

NEW WATER LINE CROSSES AN EXISTING PRESSURE RATED WASTEWATER MAIN
LOCATION OF WATER LINES - CROSSING LINES

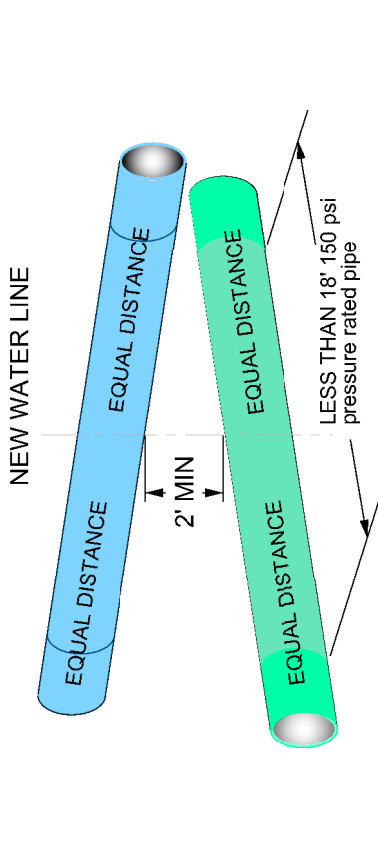
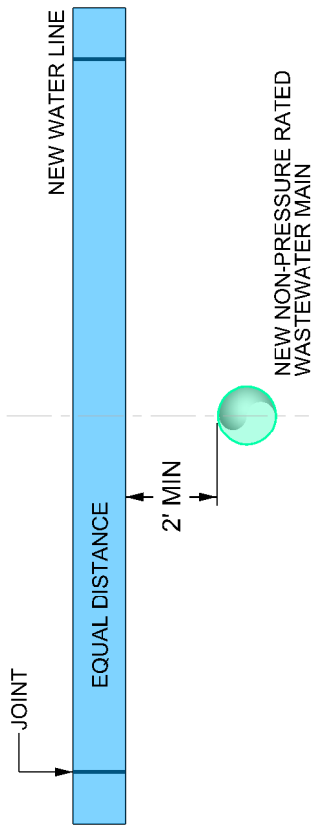

NEW NON-PRESSURE RATED WASTEWATER MAIN

NEW WATERLINE CROSSES A NEW PRESSURE RATED WASTEWATER MAIN
LOCATION OF WATER LINES - CROSSING LINES

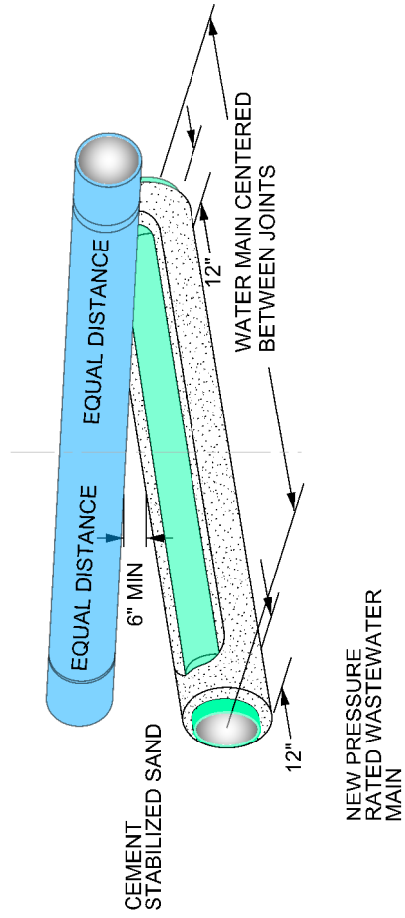
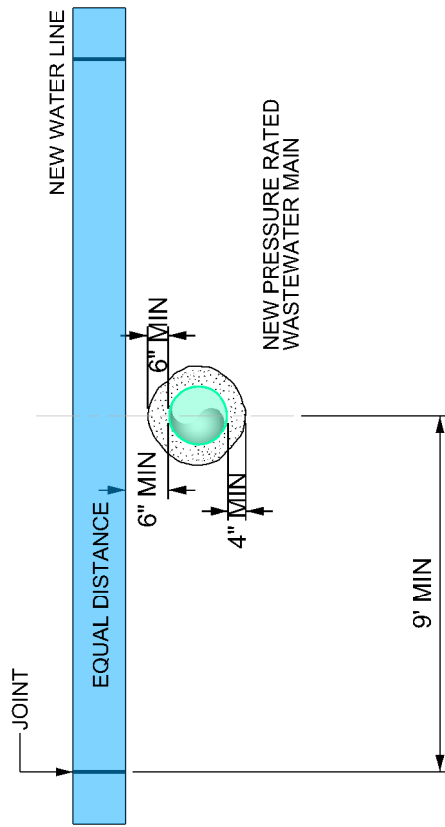

NEW PRESSURE RATED WASTEWATER MAIN

NEW WATER LINE CROSSES A NEW NON PRESSURE RATED WASTEWATER MAIN
 LOCATION OF WATER LINES - CROSSING LINES

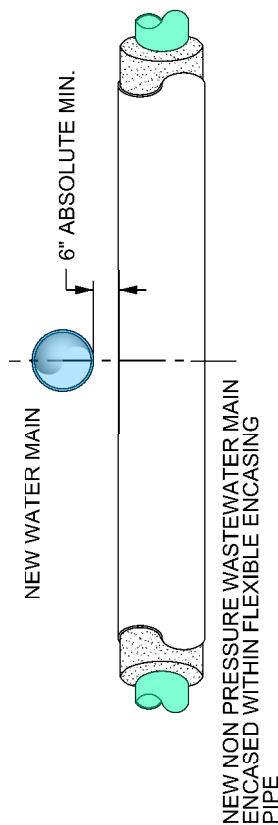

LOCATION OF WATER LINES - CROSSING LINES

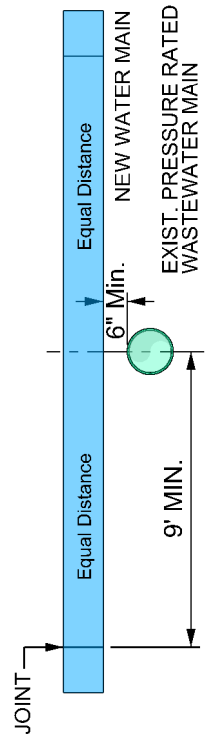

NEW WATER LINE CROSSES A NEW NON-PRESSURE RATED WASTEWATER MAIN

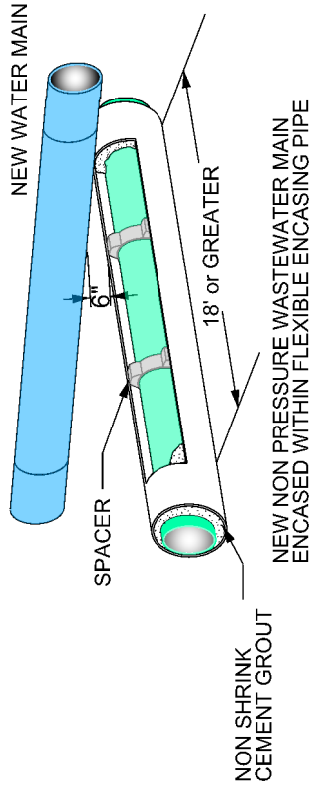
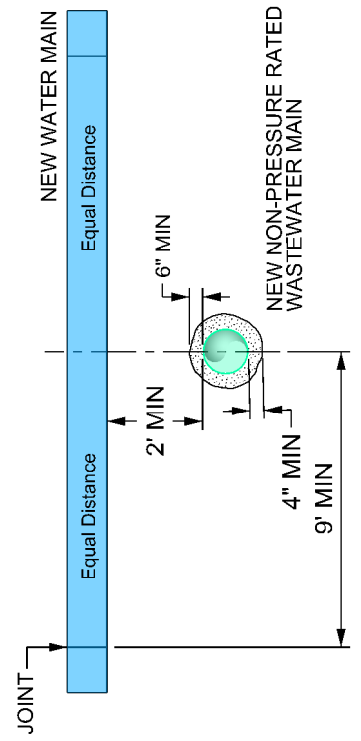

NEW NON PRESSURE WASTEWATER MAIN
 ENCASED WITHIN FLEXIBLE ENCASING PIPE

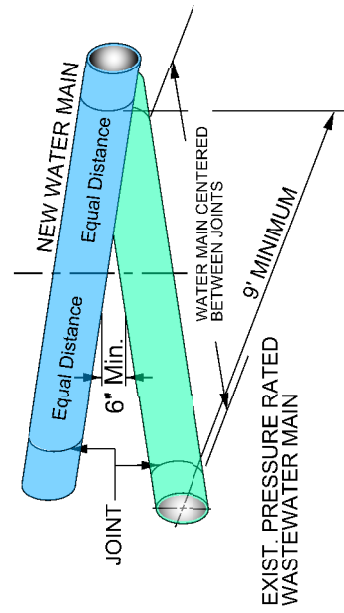

EXIST. PRESSURE RATED
 WASTEWATER MAIN

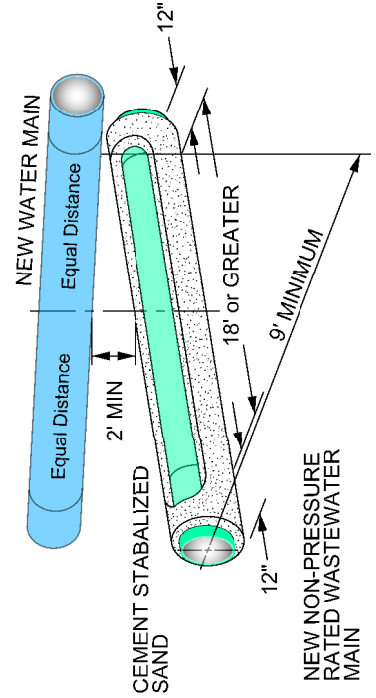

NEW NON-PRESSURE
 RATED WASTEWATER
 MAIN

NEW WATER LINE CROSSES UNDER A WASTEWATER MAIN
 LOCATION OF WATER LINES - CROSSING LINES

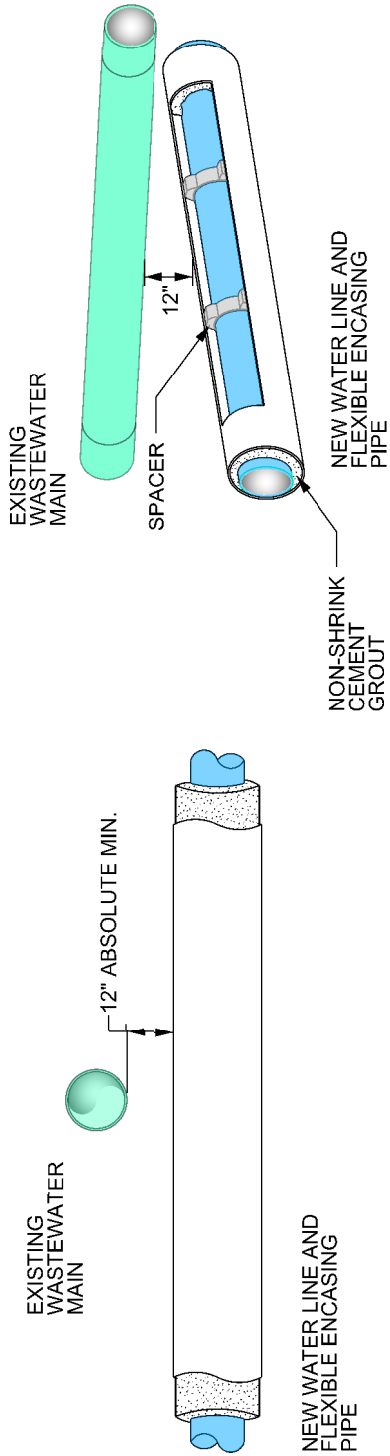

WATERLINE AND WASTEWATER MAIN OR LATERAL MANHOLE OR CLEANOUT SEPARATION
 CLEANOUT SEPARATION

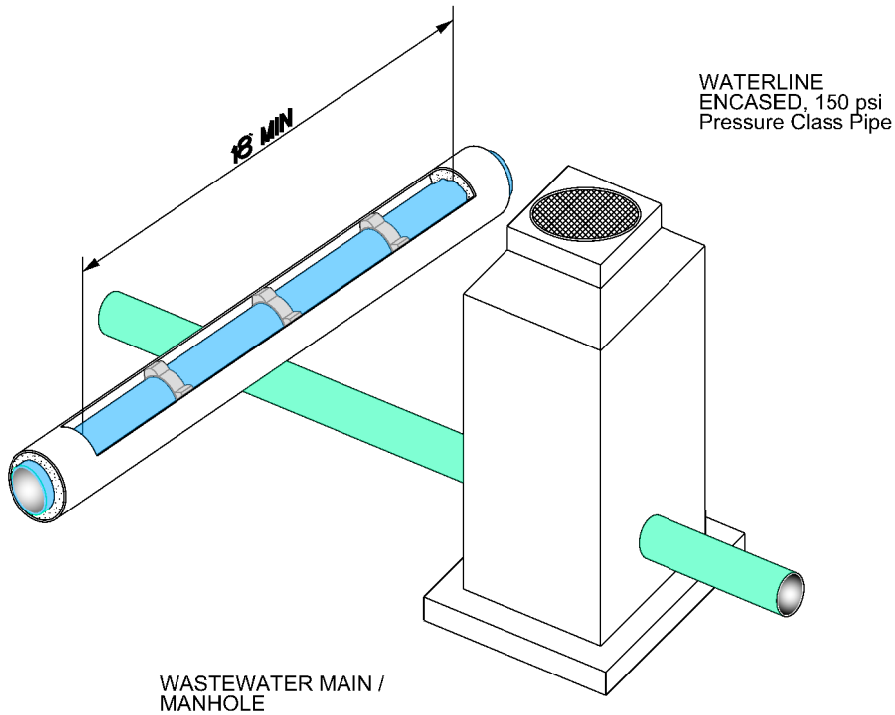
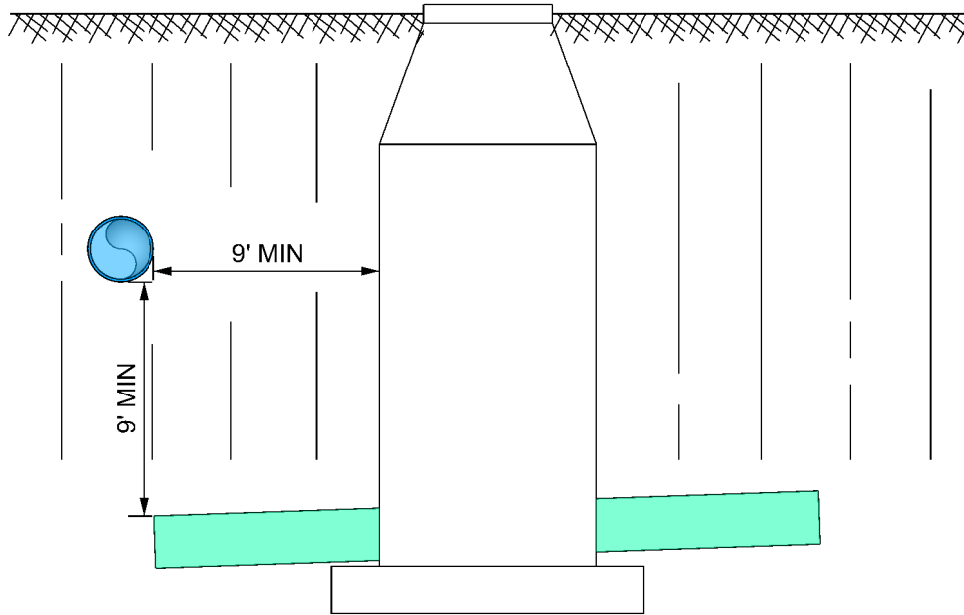

WATERLINE AND WASTEWATER MAIN OR LATERAL MANHOLE OR CLEANOUT SEPARATION
 LOCATION OF FIRE HYDRANTS

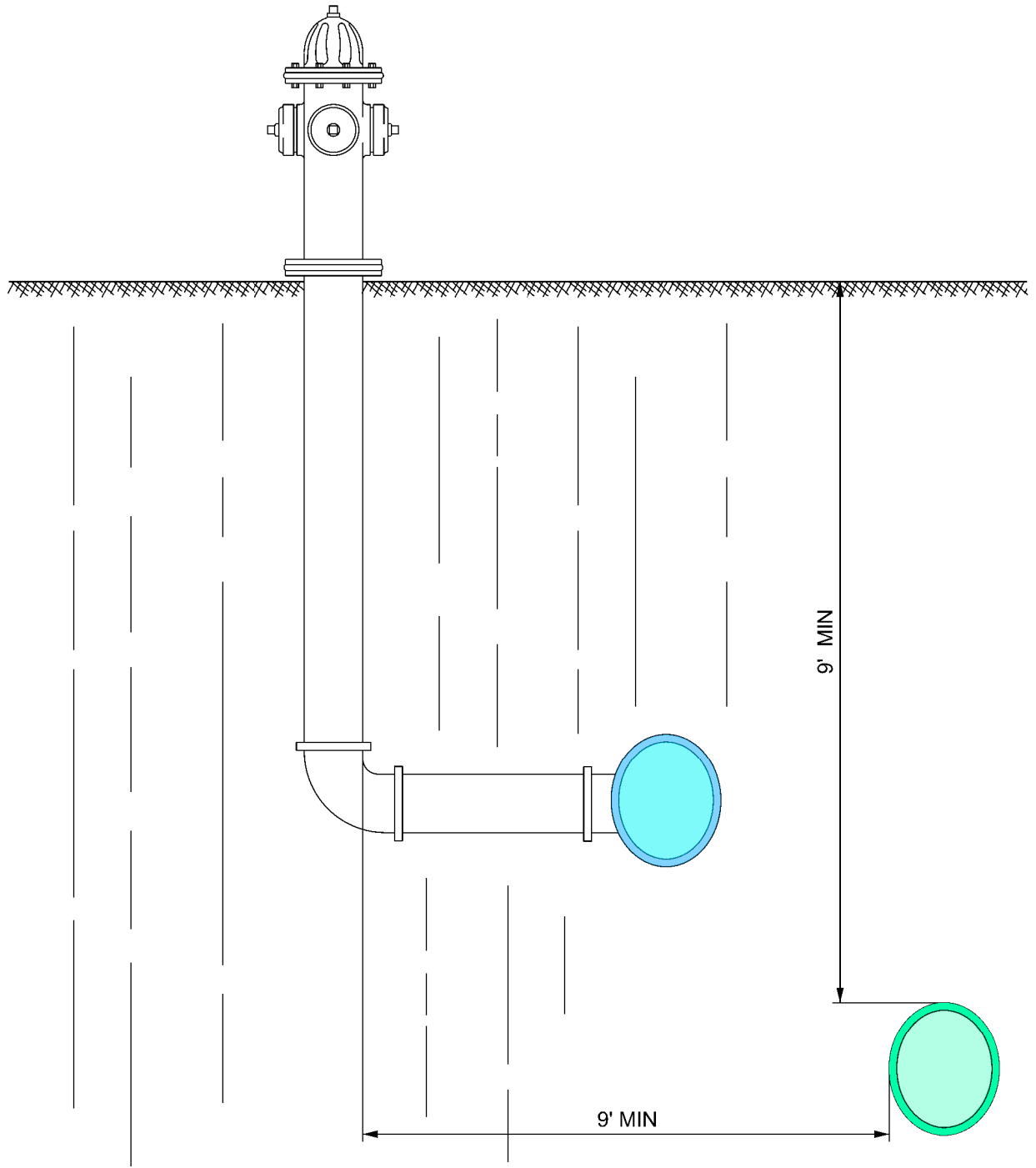

PROPERTY OF SAN ANTONIO WATER SYSTEM SAN ANTONIO, TEXAS	FIRE HYDRANT WITH MAIN GREATER THAN 6 FOOT DEPTH	APPROVED	REVISED
			AUG 2019
		DD-812-01	SHEET 8 OF 9

SANITARY SEWER RELIEF LINE

RELIEF SEWERS - AN OVERLOADED EXISTING SANITARY SEWER MAY REQUIRE RELIEF, WITH THE RELIEF SEWER CONSTRUCTED PARALLEL TO THE EXISTING LINE TO DIVERT FLOWS TO ALTERNATE OUTLETS.

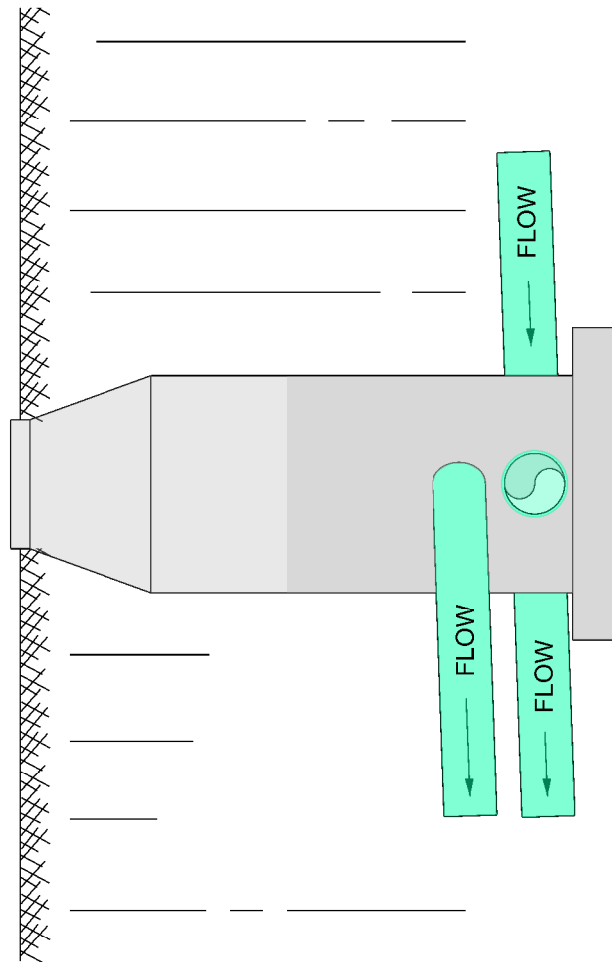

ELEVATION VIEW - SEWER RELIEF LINE

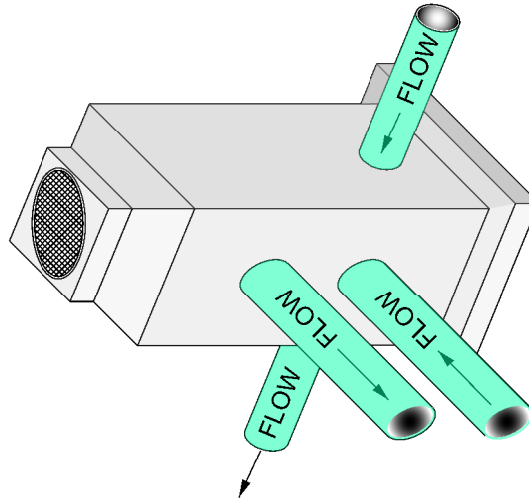

ISOMETRIC VIEW - SEWER RELIEF LINE

San Antonio Water System Standard Specifications for Construction

ITEM NO. 822

Customer's Water Yard Pipe

822.1 DESCRIPTION: This item shall consist of customer yard piping adjustments and installation in accordance with these specifications and as directed by the Engineer.

822.2 REFERENCE STANDARDS: Reference standards cited in this Specification Item No. 822 refer to the current reference standard published at the time of the latest revision date.

1. San Antonio Water System (SAWS):
 - a. Specifications for Water and Sanitary Sewer Construction
 - b. SAWS Materials Specifications
2. City of San Antonio (COSA) Standard Specification for Construction
3. Texas Commission of Environmental Quality (TCEQ)
 - a. TCEQ 290 Rules and Regulations for Public Regulations for Public Water Systems
4. American Waterworks Associations
 - a. AWWA C 800 - Standard for Underground Service Line Valves and Fittings

822.3 SUBMITTALS: All submittals shall be in accordance with most recent version of SAWS's General Conditions requirements. Submit the following prior to performing any work.

1. Certifications:
 - a. Per General Conditions section 5.12.2 all Contractor submittals for all pipe and other products or materials furnished under this specification shall be marked as reviewed and approved by Contractor for compliance with Contract Documents and the referenced standards.
 - b. The Manufacturer shall provide ISO 9001 Certificate by a third party.
 - c. Submit written verification from the pipe Manufacturer demonstrating compliance with the production and delivery schedule of the pipe as indicated in the Contractor's schedule.
2. Contractor shall submit Manufacturer's product data, installation recommendations, shop drawings, and certifications.
3. Shop Drawings:
 - a. Catalog Data Sheets for all materials confirming pipe, fittings, and other materials conform to requirements of this specification.
 - b. Pipe Supplier Information. Submit company name, contact name, and contact number.
 - c. Details of all piping systems components confirming that the pipe and fittings conform to the specified requirements.

San Antonio Water System Standard Specifications for Construction

822.4 MATERIALS: The materials for customer water yard piping adjustments and installation shall conform to the specifications contained within the latest revision of SAWS' Material Specification Item No. 19-01 "HDPE Tubing" and 15-40, "Brass Goods."

1. Materials shall include DR 9 HDPE CTS tubing, and Certa T-Lock PVC.
2. All ¾ inch through 2 inch yard piping shall be furnished by the Contractor.
3. Use PVC schedule 80 for casing (2" and 3"), Certa T-lock PVC or steel pipe for larger casing 4" and up
4. Plastic round Customer cut-off valve boxes furnished by the Contractor shall consist of a box and cover, shall accommodate cut-off valves up to 2 inches, and shall be by a SAWS-approved manufacturer.

822.5 CONSTRUCTION:

1. Designation of Yard Piping:
 - a. New customer water yard piping shall be installed within the limits of the Customer's property in conjunction with all small service lines relocated from existing mains in the alleyways behind Customer residences to street rights-of-ways fronting Customer residences. See Standard Drawing DD-822.
 - b. Customer yard piping begins from the outlet meter connection to the point of connection within the limits of the Customer's lot or property.
 - c. "Short yard piping," shall be described as consisting of customer's yard piping that does not exceed one-half the depth of the lot.
 - d. "Long yard piping," shall be described as consisting of customer's yard piping that, when installed, exceeds one-half depth of the lot.
2. The Contractor shall also furnish all materials to include pipes, nipples, unions, couplings, tees, elbows, street ells, hose bibs, stiffner, insulation for riser pipe, caps, plugs and appurtenances required to complete the tie of Customer's new yard piping at the new point of connection and the abandonment of the Customer's old yard piping at the old point (NSP).
3. All HDPE tubing shall have a stiffner at connection.
4. Where dissimilar materials are to be connected, the Contractor shall install a PVC Schedule 80 insulator coupling.
5. Work involved with replacing existing yard piping shall consist of at a minimum several key components as listed:
 - a. Excavation of miscellaneous material encountered;
 - b. Installation of the new yard piping with 12 inches of cover minimum and in the most direct and practicable alignment;
 - c. Brass fittings;
 - d. Customer's cut-off valve and the Customer's cut-off valve box;
 - e. Reconnection of the Customer's service at the relocated meter and the new point of connection within the limits of the Customer's property
 - f. Abandoning the Customer's old yard piping by cutting and plugging the old yard piping at the old point of connection within the limits of the Customer's property;

San Antonio Water System Standard Specifications for Construction

- g. As per Specification Item No. 804 Excavation, Trenching and Backfill, backfilling the trench with approved selected material and disposal of surplus excavated material;
 - h. As per Specification Item No. 804 Excavation, Trenching and Backfill, replacement of surfaces of all types over the completed yard piping trench with approved selected material and disposal of surplus excavation material;
 - i. Restoration of the site. Existing trees, plants or shrubbery within the Customer's property shall not be disturbed.
 - j. Any existing landscape that necessitates removal, in order for the scope of work to be completed, shall be replaced to the satisfaction of the inspector and customer at the Contractor's expense;
 - k. Acquiring any permits to do this scoped work on the customer's property.
 - l. Pressure Reducing Valve (PRV) and PRV valve box
- 6. When a manifold systems are encountered, the Contractor shall install and tie-in Customer yard piping at the existing point of connection. Lawn sprinklers are a possible indication of existing manifold systems.
 - 7. All exposed risers shall be protected from freezing temperatures by means of keeping them no less than 6 inches below ground surface to the tie-in.
 - 8. Trench excavation may be accomplished either manually, mechanically (such as usage of a "Ditch Witch"), or by other similar mechanical trenching equipment.
 - 9. If mechanical trenching equipment is utilized, depressions or damage to lawn areas caused by crawler track pads or pneumatic tires shall be repaired and restored to their original condition or better condition.
 - 10. Lawn turf over the trench shall be removed squarely to a depth of 2 inches and in lengths not to exceed 36 inches.
 - 11. Lawn turf removed and material excavated from the trench area shall not be placed directly upon existing lawn turf areas, but rather, they shall be separated and placed on building paper or plastic membrane.
 - 12. Building paper or plastic membrane shall cover the existing lawn turf adjacent and parallel to the alignment followed by the trench.
 - 13. After the installation of the yard piping, the trench shall be backfilled and adequately tamped in two compacted lifts of 5 inches and watered.
 - 14. The lawn turf shall be replaced, adequately tamped, and thoroughly watered after surplus soil is removed. If the lawn turf was damaged during removal or storage, new turf shall be installed to match the turf of the adjacent lawn at Contractor's expense.
 - 15. Customer's yard piping shall be flushed prior to final tie-in at the existing point of connection.

822.6 MEASUREMENT: "Customer's Yard Piping" will be measured by yard piping designations, Long and Short Yard Piping.

822.7 PAYMENT: Payment for "Customer's Yard Piping" will be made at the unit bid price bid per for "Short yard piping" or "Long yard piping."

- 1. Such payment shall also include: excavation, hauling and disposition of surplus material, approved backfill material, removal and replacement of Customer's lawn turf, permits, and any other surface vegetation/landscaping and surface structure

San Antonio Water System Standard Specifications for Construction

- encountered, yard piping, stiffeners, customer cut off box and valve, and brass fittings of necessary size to complete the tie at the Customer's point of connection, PRV, Customer Valve, and required appropriate sized boxes
2. Materials paid on site will be in accordance with Table 1 of Specification Item No. 100 Mobilization

-End of Specification-

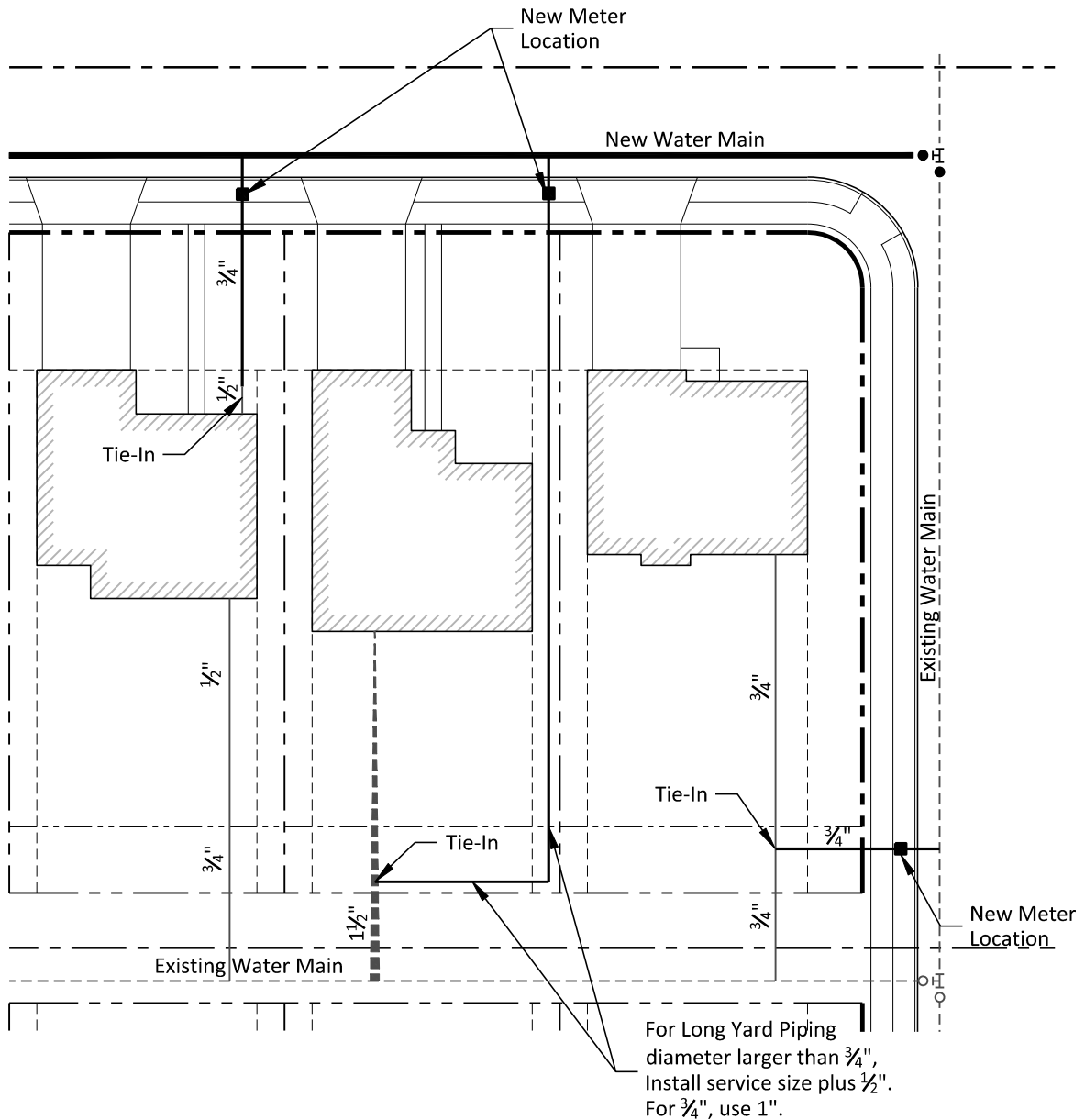

Notes:

1. Customer's yard piping consists of water supply piping and appurtenances between the customer's side of the Cut-Off Valve and Box and the nearest point of the largest existing connection within the customer's property.
2. Yard piping alignment shall be established in the field by Inspector.
3. Existing customer's yard piping to the abandoned main shall be cut and capped inside the customer's property.
4. Yard Piping pay item:
 - A. Short Yard Piping: When yard piping is less than 1/2 the depth of the lot.
 - B. Long Yard Piping: When yard piping is more than 1/2 the depth of the lot.
5. Install SCH 80 PVC Coupling at the location where dissimilar pipe material is encountered.

PROPERTY OF SAN ANTONIO WATER SYSTEM SAN ANTONIO, TEXAS	RELOCATE SERVICE OF CUSTOMER'S YARD PIPING	APPROVED	REVISED
		JUNE 2020	August 2020
		DD-822-01	

San Antonio Water System Standard Specifications for Construction

ITEM NO. 824

Water Service Supply Lines Service Relays

824.1 DESCRIPTION: This item shall consist of Water Service Supply Lines Service Relays adjustment and installation in accordance with these specifications and as directed by the Engineer.

824.2 REFERENCED STANDARDS: Reference standards cited in this Specification Item No. 824 refer to the current reference standard published at the time of the latest revision date.

1. San Antonio Water System (SAWS):
 - a. Specifications for Water and Sanitary Sewer Construction
 - b. SAWS Materials Specifications
2. City of San Antonio (COSA) Standard Specification for Construction
3. Texas Commission of Environmental Quality (TCEQ)
 - a. Chapter 290; Subchapter D – Rules and Regulations for Public Drinking Water
4. American National Standards Institute (ANSI)/American Water Works Association (AWWA)
 - a. ANSI/AWWA C105/A21.5—Polyethylene Encasement for Ductile-Iron Pipe Systems.
 - b. ANSI A 21.11/AWWA C111 - Standard for Rubber-Gasket Joints for Ductile-Iron Pressure Pipe and Fittings.
 - c. ANSI/AWWA C150/A21.50—Thickness Design of Ductile-Iron Pipe.
 - d. ANSI/AWWA C151/A21.51—Ductile-Iron Pipe, Centrifugally Cast.
 - e. ANSI/AWWA C500—Metal-Seated Gate Valves for Water Supply Service.
 - f. ANSI/AWWA C515—Reduced-Wall, Resilient-Seated Gate Valves for Water Supply Service.
 - g. ANSI/NSF Standard 61 - Drinking Water System - Health Components
 - h. AWWA C 206 - Standard for Field Welding of Steel Water Pipe.
 - i. AWWA C 207 - Standard for Steel Pipe Flanges for Waterworks Service - Sizes 4 Inches through 144 Inches.
 - j. ANSI/AWWA C509—Resilient-Seated Gate Valves for Water Supply Service.
 - k. AWWA C605, “Underground Installation of Polyvinyl Chloride (PVC) Pressure Pipe and Fittings for Water
 - l. AWWA C651 Disinfecting Water Mains
 - m. AWWA C900, “Polyvinyl Chloride (PVC) Pressure Pipe And Fabricated Fittings, 4 In. Through 60 In. (100 Mm Through 1,500 Mm for Water Distribution”

San Antonio Water System Standard Specifications for Construction

- n. AWWA C907, “Polyvinyl Chloride (PVC) Pressure Fittings for Water –4 in. through 8 In (100 mm Through 200 mm)
- o. AWWA Manual M27, External Corrosion: Introduction to Chemistry and Control.
- p. AWWA M28 Rehabilitation of Water Mains
- q. AWWA Manual M41—Ductile-Iron Pipe and Fittings
- 5. American Society for Testing and Materials (ASTM) International:
 - a. ASTM A 36 - Standard Specification for Carbon Structural Steel.
 - b. ASTM A 536 - Standard Specification for Ductile Iron Castings.
 - c. ASTM A 126 - Standard Specification for Gray Iron Castings for Valves, Flanges, and
 - d. Pipe Fittings.
 - e. ASTM B 21 - Standard Specification for Naval Brass Rod, Bar, and Shapes.
 - f. ASTM B 98 - Standard Specification for Copper-Silicon Alloy Rod, Bar, and Shapes.
 - g. ASTM B 301 - Standard Specification for Free-Cutting Copper Rod and Bar.
 - h. ASTM B 584 - Standard Specification for Copper Alloy Sand Casting for General Application.
 - i. ASTM E 165 - Standard Test Method for Liquid Penetrant Examination.
 - j. ASTM E 709 - Standard Guide for Magnetic Particle Examination.
 - k. ASTM F 1674 - Standard Test Method for Joint Restraint Products for Use with PVC Pipe.
- 6. International Organization of Standardization (ISO)
 - a. ISO9001

824.3 SUBMITTALS: All submittals shall be in accordance with most recent version of SAWS’s General Conditions requirements. Submit the following for approval prior to performing any work.

- 1. Certifications:
 - a. Per General Conditions section 5.12.2 all Contractor submittals for all pipe and other products or materials furnished under this specification shall be marked as reviewed and approved by Contractor for compliance with Contract Documents and the referenced standards.
 - b. The Manufacturer shall provide ISO 9001 Certificate by a third party.
 - c. Submit written verification from the pipe Manufacturer demonstrating compliance with the production and delivery schedule of the pipe as indicated in the Contractor’s schedule.
 - d. Contractor shall submit Manufacturer’s product data, installation recommendations, shop drawings, and certifications.
 - e. Shop Drawings

San Antonio Water System Standard Specifications for Construction

- f. Catalog Data Sheets for all materials confirming pipe, fittings, and other materials conform to requirements of this specification.
- g. Pipe Supplier Information. Submit company name, contact name, and contact number.
- h. Details of all piping systems components confirming that the pipe and fittings conform to the specified requirements.

824.4 MATERIALS: The materials for water service supply lines installation and adjustment shall conform to the specifications contained within the latest revision of SAWS' Material Specification Item Nos. 21-10, "Brass Gate Valves," 15-40, "Brass Goods", 19-01 HDPE Tubing and 100-30, "Service Saddles," 10-30 Water Meter Boxes (5/8", 3/4", 1", 1-1/2" AND 2" Meters).

824.5 CONSTRUCTION:

1. General: Service supply lines and fittings, meter boxes and appurtenances shall conform to the Material Specifications and shall be installed by the Contractor as specified herein, or as directed by the Engineer and in accordance with the DD-824 Standard Drawing Series.
 - a. All services shall be in line with meter box location, any variance requires prior approval from SAWS' Inspector.
 - b. Tracer wire shall be utilized for location and taped directly to the pipe.
 - i. Tracer wire shall be properly spliced at each end connection and each service connection.
 - ii. Tracer wire shall be adequately wrapped and protected at each splice location in accordance with manufacturer recommendations.
 - iii. No bare tracer wire shall be accepted.
 - iv. Wire shall also come up to the top of valve extensions and fire hydrant stems, as directed by the Inspector.
 - v. Tracer wire shall be utilized for location purposes and taped directly to the top of pipe.
 - vi. Tracer wire shall be of solid core (14 gauge insulated), and shall be taped to the main in minimum of 10 inch increments.
 - vii. Detection tape cannot be used in lieu of tracer wire.
2. Service Relays:
 - a. A service relay is defined as a new material laid from the main to the inlet side of the existing meter
 - b. New distribution main(s) to which services are to be relayed, and are on the same side of the streets as the Customer's meter, are defined as "short relays."
 - c. New distribution main(s) to which services are to be relayed, and are on the opposite side of the street from the Customer's meter, are defined as "long relays."

San Antonio Water System Standard Specifications for Construction

3. Tap Holes: Tap holes are defined as excavations at existing mains, which are required in association with replacements of water service lines by pulling, boring or jacking operations.
 - a. All backfill material shall be as specified for all associated main and service line trench excavation, as specified in Specification Item No. 804 "Excavation, Trenching, and Backfill."
 - b. For service lines and tap holes, payment for bedding, initial backfill and secondary backfill shall be included in the various sizes of each service placed.
4. Service Line Installation: Unless otherwise notified, service relays shall be installed as described herein, and in the DD-824 Standard Drawing Series.
 - a. Unless otherwise indicated, existing meter and meter box relocation shall be included in the service line installation.
 - b. All service lines longer than 60 ft. in length in concrete pavement in major thoroughfares crossings shall be installed in Schedule 80 PVC conduit.
 - c. Cutting, excavation, backfill and replacement of pavement shall be done as specified herein and in accordance with applicable sections of the City of San Antonio Specification Item No. 511, "Cutting and Replacing Pavements (Trench Repair), and Specification Item No. 804, "Excavation, Trenching, and Backfill."
 - d. The maximum trench width for small service lines shall be 8 inches, while the minimum trench width for large service lines shall be the nominal pipe diameter plus 16 inches, except when specified otherwise by the Engineer. Trench shall be filled with flowable fill at NSPI.
 - e. For $\frac{3}{4}$ inch to 2 inch service lines, the minimum bury depth shall be 3 feet.
 - f. For services greater than 2 inches, the minimum depth of bury shall be 4 feet.
 - g. All service lines shall be installed in accordance with the DD-824 Standard Drawing Series, SAWS' Standard Material Specification Item No. 100-30, with two strap service saddle clamps for all taps services.
 - h. The Contractor shall use precaution to protect and preserve the polyethylene wrap around ductile-iron water mains when installing service saddles and service corporations.
 - i. The required method is wrap pipe tape around the pipe, over the polywrap, after the service saddle and service corporation has been installed.
 - j. HDPE shall have stiffeners installed per manufactures' recommendation.
 - k. The tap shall be made through the tape and polywrap. It is not necessary to remove and replace polywrap.
 - l. All exposed pipe, corporation, and the first three feet of the service, shall be wrapped and taped to achieve a complete seal. In addition, a sand envelope shall extend over and around the connection to a depth of 8 inches above the main.
 - m. Small service lines shall be embedded in sand in accordance with Specification Item No. 804, "Excavation, Trenching and Backfill."

San Antonio Water System Standard Specifications for Construction

- n. When approved by the Inspector, the Contractor may lay the new service line from the corporation stop to the curb stop or angle valve.
- o. Upon completion, the Contractor shall isolate the new service line by closing the curb stop or angle valve until the meter box is set.
- 5. Splicing: A long service line single slice may be permitted only when approved in advance by the Inspector, provided the location of the splice is not under pavement or concrete.
 - a. The segment added is required to be the same material as the existing service line, unless otherwise directed by the Inspector.
 - b. Splicing short service lines will not be permitted.
- 6. Directional Drilling: Service lines which cross paved streets may be installed at the Contractor's option by boring or jacking operations at no additional cost to SAWS. PVC schedule 80 shall be used for casing (2" and 3"), Certa-T lock or steel pipe shall be used for larger casing 4" and up.
- 7. Tapping Asbestos Cement (AC) Pipe: Direct tapping will not be allowed. Service saddles must be used when tapping AC pipe.
 - a. Drill tools shall be used for services less than 2 inches.
 - b. Shell type drills shall be used for all services 2 inches and greater.
 - c. The tapping of AC pipe must be done in accordance with manufacturers' recommendations and done only with tap machine having a built in flush valve and the flush valve must be open during the entire procedure.
- 8. Abandonment of Service Lines: The Contractor shall accomplish all cutting, capping, and plugging necessary to isolate new service lines transferred to new and existing mains from those abandoned, including service lines designated in the contract documents as "tap plug".
 - a. The corporation stop for an abandoned service line tapped on a ferrous main shall be removed, and the tap at the main shall be plugged with an appropriately sized brass plug.
 - b. For a non-ferrous main, the corporation stop shall not be removed from the main. Instead, the corporation stop shall be closed and the flared nut shall be removed from the corporation stop.
 - c. After the appropriately sized copper disc is inserted inside the flared nut, replace the flared nut on the corporation stop.
- 9. Tapping PVC (C-900) Pipe: Tapping of PVC pipe must be done in accordance with Uni-Bell procedures.
 - a. Direct tapping will not be allowed. All drill cutting tools must be the "shell type" with internal teeth or double slots which will retain the coupon.
 - b. The shell cutters must be designed for C-900 pipe, thus having sufficient root depth to handle the heavier walled pipe.
- 10. Small Service Lines:
 - a. HDPE tubing shall be used for ¾ inch through 2 inch service lines.
 - b. Brass fittings for ¾ inch and 1 inch service lines shall be of compression type for the use with HDPE tubing.
 - c. Brass fittings for 1½ inch and 2 inch lines shall be of compression type for use with

San Antonio Water System Standard Specifications for Construction

- d. HDPE tubing, except as modified in this specification. Tubing shall be cut squarely by using an approved cutting tool and by avoiding excessive pressure on the cutting wheels which might bend or flatten the pipe walls.
 - e. Tubing shall be cut squarely and burred.
 - f. Pipe adjacent to the fittings shall be straight for at least 10 inches.
 - g. Bending of tubing shall be accomplished by using an appropriate sized bending tool. No kinks, dents, flats, or crimps will be permitted, and should such occur, the damaged section shall be replaced.
 - h. When compression fittings are used, the copper tubing shall be cut squarely prior to insertion into the fitting.
 - i. Final assembly shall be in accordance with the manufacturer's recommendations.
11. Relaying Service Lines: The existing or new mains shown in the contract documents shall be exposed and opposite location stakes placed onsite at the direction of the Inspector.
- a. The existing or new main shall: be drilled and tapped with an approved tapping machine, a new corporation stop installed, and the trench extended laterally to the location specified for the meter box.
 - b. The existing meter shall be reset and the meter box and base shall be installed at its staked location and perpendicular to the corporation stop in the water main.
 - c. The meter box location shall not vary more than 2 feet laterally from its existing location.
 - d. Meter box is to be located within the ROW.
 - e. The service line shall be installed with sufficient slack to compensate for soil movement.
 - f. Where the location of the existing meter is not changed, the new service line shall be extended from the main to the existing meter, a new curb stop installed at the end of the service line, and connected to the inlet side of the meter.
 - g. If disturbed, the existing meter box shall be reset to correct grade.
 - h. Long service relays may be placed under the street pavement by boring or jacking rather than trenching.
12. Single Service Line - Dual Meters: The single service line - dual meter installation shall consist of a 1" service line reducing to two $\frac{3}{4}$ inch service lines at a tee which shall be set in line with the front edge of meter boxes for $\frac{5}{8}$ inch and $\frac{3}{4}$ inch meters. Dual Meters shall be for new development only.
- a. A single service line with dual meters shall be installed in those new residential developments where new $\frac{5}{8}$ inch and $\frac{3}{4}$ inch meters are required and in main replacement work, where it is necessary to change the location of existing $\frac{5}{8}$ inch and $\frac{3}{4}$ inch meters.
 - b. Single service line - dual meter materials and installation requirements shall conform to requirements established herein See DD-824 Drawing Series.

San Antonio Water System Standard Specifications for Construction

- c. No branching will be allowed on services that require pressure reducing valves (PRVs).
13. Small Service Lines on Existing Mains: The work involved in the installation of relaying service lines on existing mains shall consist of jacking, boring, tunneling, and, open trench operations; all excavation through any material encountered; trench excavation protection; using the existing corporation when approved by the Inspector; tapping the existing main and relaying the service line at the same grade as the existing service line or at the specified grade between the main and the existing meter and its tie-in at the corporation and the curb stop; disposal of surplus excavated material; capping the tap hole with asphalt treated base including the outer limits of the main line trench and the service line trench; cutting and replacing all surfaces of all type encountered over the completed service line trench; restoration of the site.
14. Large Service Lines: Ductile iron pipe, HDPE, and PVC fittings used for metered service lines and non-metered fire service lines larger than 2 inch shall be installed in accordance with the applicable provisions of Specification Item No. 812, "Water Main Installation," except where otherwise approved by the Engineer. Fire lines shall be ductile iron only.
15. Large Service Lines on New Mains: Work involved in the relaying of metered service lines and non-metered fire service lines shall consist of all excavation through all material encountered, trench excavation protection, installing tees, pipe and fittings of various sizes including main line and service line valves, valve boxes, ductile iron pipe, PVC, HDPE, fittings, in accordance with the associated DD-824 Drawing Series, and reaction block, backfilling with approved selected material, cutting and replacing pavements, curbing, and sidewalks of all types over the limits of the main line trench and the completed service line. Fire lines shall be ductile iron only.
16. Large Service Lines on Existing Mains: The work involved in the relaying of the new metered service lines and non-metered fire service lines shall consist of all excavation through all material encountered, trench excavation protection, cutting-in tees and installing tapping sleeves and valves, pipe and fittings of various sizes including main line and service valves, valves boxes, ductile iron pipe, PVC, HDPE, fittings and reaction block required, backfilling with approved selected material, cutting and replacing pavements, curbing, and sidewalks of all types over the limits of the main line trench and the completed service line. Fire lines shall be ductile iron only.

824.6 MEASUREMENT:

1. Relay Short Service will be measured by the unit of the various types and sizes of each service line relayed.
2. Relay Long Service will be measured by the unit of the various types and sizes of each service line relayed.

San Antonio Water System Standard Specifications for Construction

824.7 PAYMENT:

1. Payment for a Relay Short Service will be made at the unit of the various types and sizes of each service line relayed.
 - a. Such payment shall also include trench excavation protection, hauling and disposition of surplus excavated materials, initial and secondary backfill, flowable fill, sand backfill, cutting pavement and surface structures of all type encountered and replacement with all type specified, and tubing and fittings of the various sizes used in the service line relay.
 - b. Connection of service to the existing meter and adjustment of the meter, meter box.
2. Payment for Relay Long Service will be made at the unit of the various types and sizes of each service line relayed.
 - a. Such payment shall also include trench excavation protection, hauling and disposition of surplus excavated materials, initial and secondary backfill, flowable fill, sand backfill, cutting pavement and surface structures of all type encountered and replacement with all type specified, and tubing and fittings of the various sizes used in the service line relay,
 - b. Connection of service to the existing meter and adjustment of the meter, meter box.

-End of Specification-

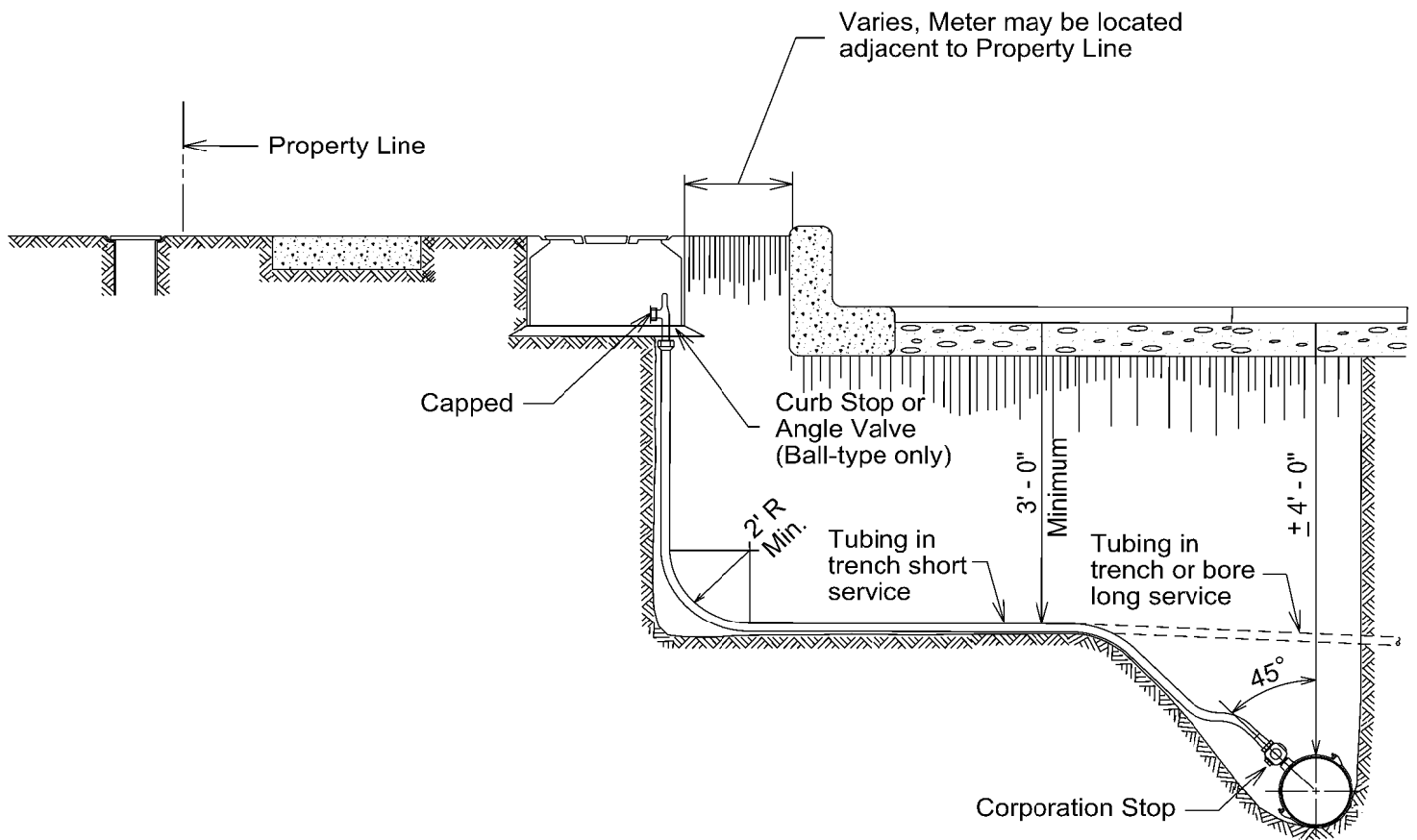

Note:
See Tapping Schedule
DD-824-01 Sheet 3 of 3

NEW NON-METERED SERVICE

PROPERTY OF
SAN ANTONIO WATER SYSTEM
SAN ANTONIO, TEXAS

**SERVICE RELAY,
SERVICE RELOCATION
3/4" THRU 2"**

APPROVED
March 2008

REVISED
AUG 2019

DD-824-23

SHEET
1 OF 1

San Antonio Water System Standard Specifications for Construction

ITEM NO. 828

Gate Valves

828.1 DESCRIPTION: This item shall consist of gate valves installed in accordance with these specifications and as directed by the Engineer.

828.2 REFERENCED STANDARDS: Reference standards cited in this Specification Item No. 828 refer to the current reference standard published at the time of the latest revision date.

1. San Antonio Water System (SAWS):
 - a. Specifications for Water and Sanitary Sewer Construction
 - b. SAWS Materials Specifications
2. City of San Antonio (COSA) Specifications for Construction
3. Texas Commission of Environmental Quality (TCEQ) Chapter 290 Public Water Supply
4. American Society for Testing and Materials (ASTM) International:
 - a. ASTM A 307 - Standard Specification for Carbon Steel Bolts and Studs, 60,000 psi Tensile.
 - b. ASTM B 62 - Standard Specification for Composition Bronze or Ounce Metal Casting.
 - c. ASTM D 429 - Standard Test Methods for Rubber Property-Adhesion to Rigid Substrates.
 - d. ASTM B 763 - Standard Specification for Copper Alloy Sand Casting for Valve Application.
5. American Water Works Association (AWWA)
 - a. AWWA C 500 - Standard for Metal-Seated Gate Valves for Water Supply Service.
 - b. AWWA C 509 - Standard for Resilient-Seated Gate Valves for Water Supply Service.
 - c. AWWA C 515- Standard for Reduced Wall, Resilient- Seated Gate Valves for Water Supply Service.
 - d. AWWA C 550 - Standard for Protective Epoxy Interior Coatings for Valves and Hydrants.

828.3 SUBMITTALS: Contractor shall submit manufacturer's product data, instructions, recommendations, shop drawings, and certifications. All submittals shall be in accordance with Engineer's requirements and submittals shall be approved prior to delivery.

828.4 MATERIALS: The materials for all gate valves shall conform to the specifications contained within the latest revision of SAWS Material Specification Item No. 21-02, "Resilient Seated Gate Valves and Tapping Valves."

828.5 CONSTRUCTION: Gate valve installation shall include: valve, reaction blocking (conforming to Standard Drawing DD-828 series), cast iron boot, valve box extension (having ductile iron riser pipe), valve box, concrete collar and valve box lid shall be

San Antonio Water System Standard Specifications for Construction

constructed with No. 3 bars all around.

1. The valve box shall be placed in such a manner to prevent shock or stress being transmitted to the valve.
2. All valves shall have operational nut within six feet of finish elevation.
3. The Contractor shall install fully adjustable valve box and valve key extension systems, on all valves located between 6 feet and 13 feet.
4. Adjustable valve box and valve key extension systems shall be centered over the valve's operating nut with the box cover flush with the finished pavement surface or located at another level as directed by the Engineer.
5. Valve boxes located in streets or other area subject to vehicular traffic shall be provided with concrete collars as shown in these standard drawings.
6. Collars around such valve boxes shall be formed and finished off neatly and in a sound workmanlike manner.
7. All valves outside of pavement area maybe subject to valve marker at the direction of the inspector at no additional payment.
8. Tracer wire shall be utilized for location and taped directly to the pipe.
 - a. Tracer wire shall be properly spliced at each end connection and each service connection.
 - b. Tracer wire shall be adequately wrapped and protected at each splice location in accordance with manufacturer recommendations.
 - c. No bare tracer wire shall be accepted.
 - d. Wire shall also come up to the top of valve extensions and fire hydrant stems, as directed by the Inspector.
 - e. Tracer wire shall be utilized for location purposes and taped directly to the top of pipe.
 - f. Detection Tape cannot be used in lieu of tracer wire.
 - g. Tracer wire shall be of solid core (14 gauge insulated), and shall be taped to the main in minimum of 10 inch increments.
9. In high pressure zones, all valves 6 inches and larger shall be supported on a concrete pad in accordance with Standard Drawings DD-828 series.

828.6 MEASUREMENT: Gate valves and valve boxes will be measured by the unit of each such assembly of the various sizes of gate valves and valve boxes installed to the finished grade.

828.7 PAYMENT: Payment for gate valves, complete with valve box, will be made at the unit price bid for each assembly of the various sizes of gate valves and valve boxes installed. Payment shall also include: excavation, selected embedment material, anti-corrosion embedment, hauling, and disposition of excavated surplus material, backfill, flowable fill, tracer wire, concrete collar at the valve box (where subjected to vehicular traffic), riser pipe, cast iron boot, packing, tar paper, concrete grout, concrete reaction blocking, protective coating material for bolts, nuts, ferrous surfaces, valve marker, and polyethylene sleeve.

1. Materials paid on site will be in accordance with Table 1 of Specification Item No. 100 Mobilization

San Antonio Water System Standard Specifications for Construction

-End of Specification-

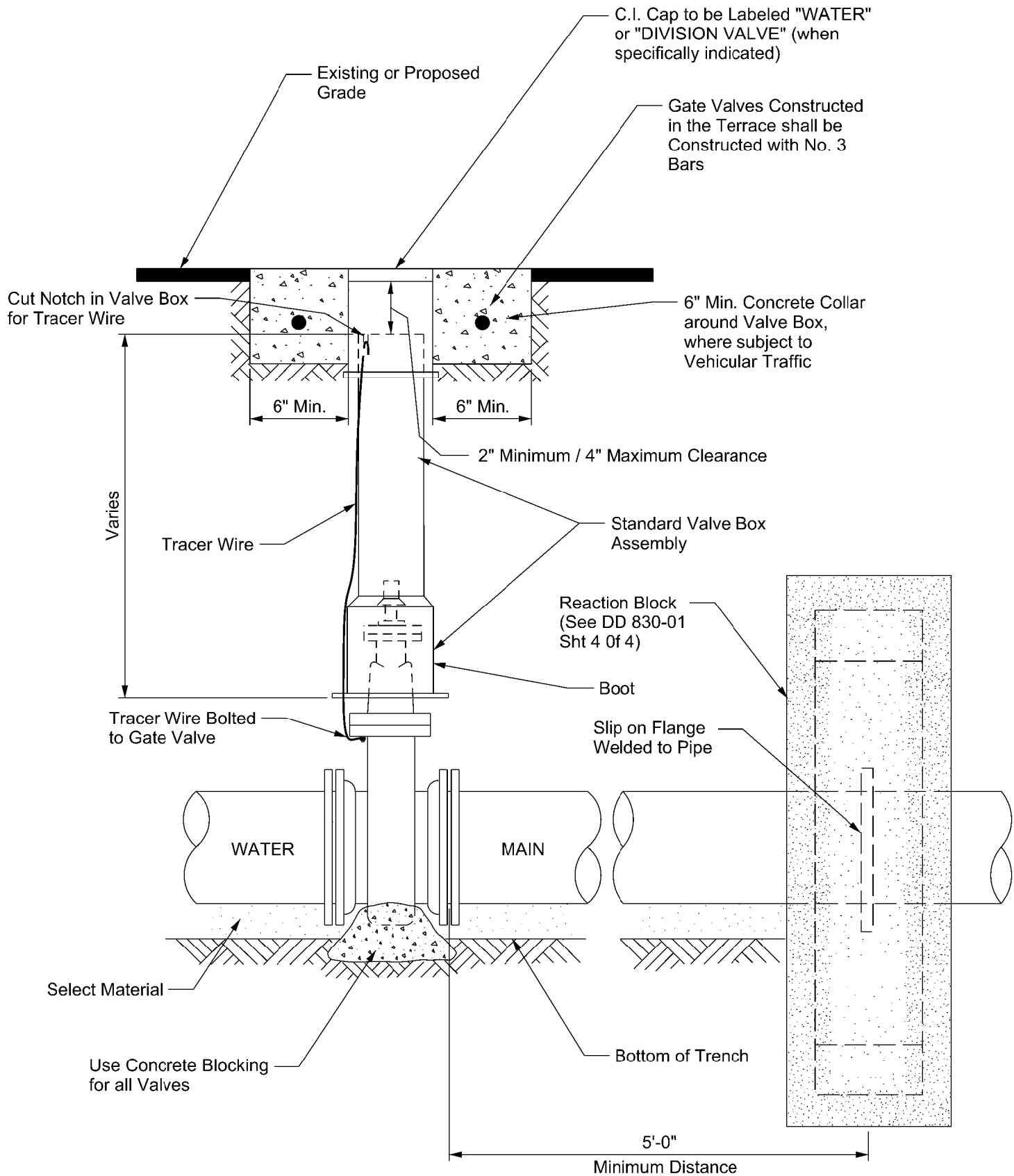

NOTE: Tracer Wire for PVC (Typ. for PVC & HDPE)
 NOTE: All Concrete to be 3,000 psi

Note: For all work associated with Recycled Water Valves, refer to DD 110-10, Sht. 1 of 1

PROPERTY OF SAN ANTONIO WATER SYSTEM SAN ANTONIO, TEXAS	INSTALLATION OF NON-GEARED GATE VALVE WITH VALVE BOX AND EXTENSION	APPROVED	REVISED
		MARCH 2008	AUG 2019
DD 828-01			SHEET 1 OF 1

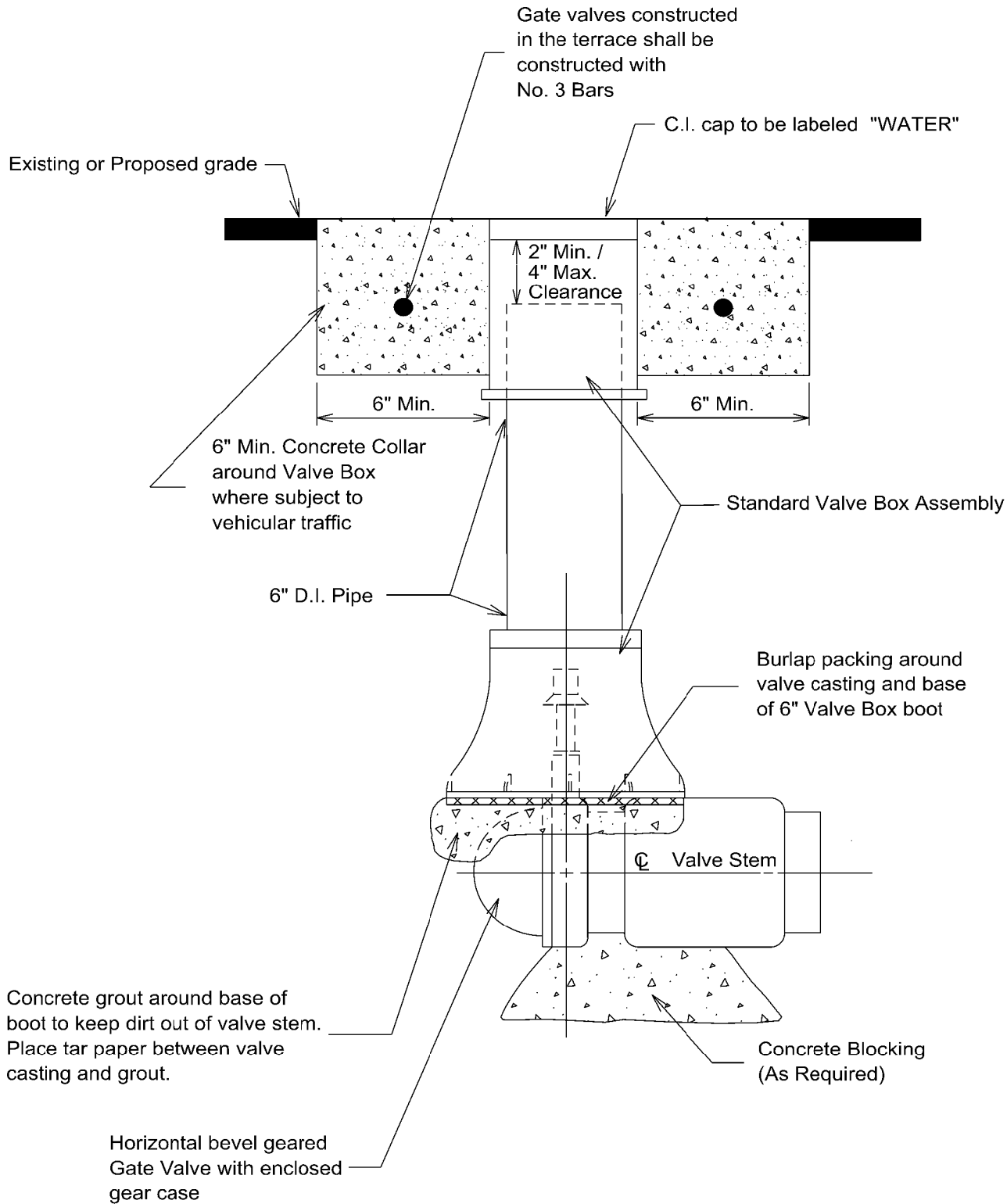

Note: All Concrete to be 3,000 psi.

PROPERTY OF
SAN ANTONIO WATER SYSTEM
 SAN ANTONIO, TEXAS

**INSTALLATION OF GEARED
 HORIZONTAL GATE VALVE
 WITH VALVE BOX COMPLETE**

APPROVED
 MARCH 2008

REVISED
 AUG 2019

DD-828-02

SHEET
 1 OF 1

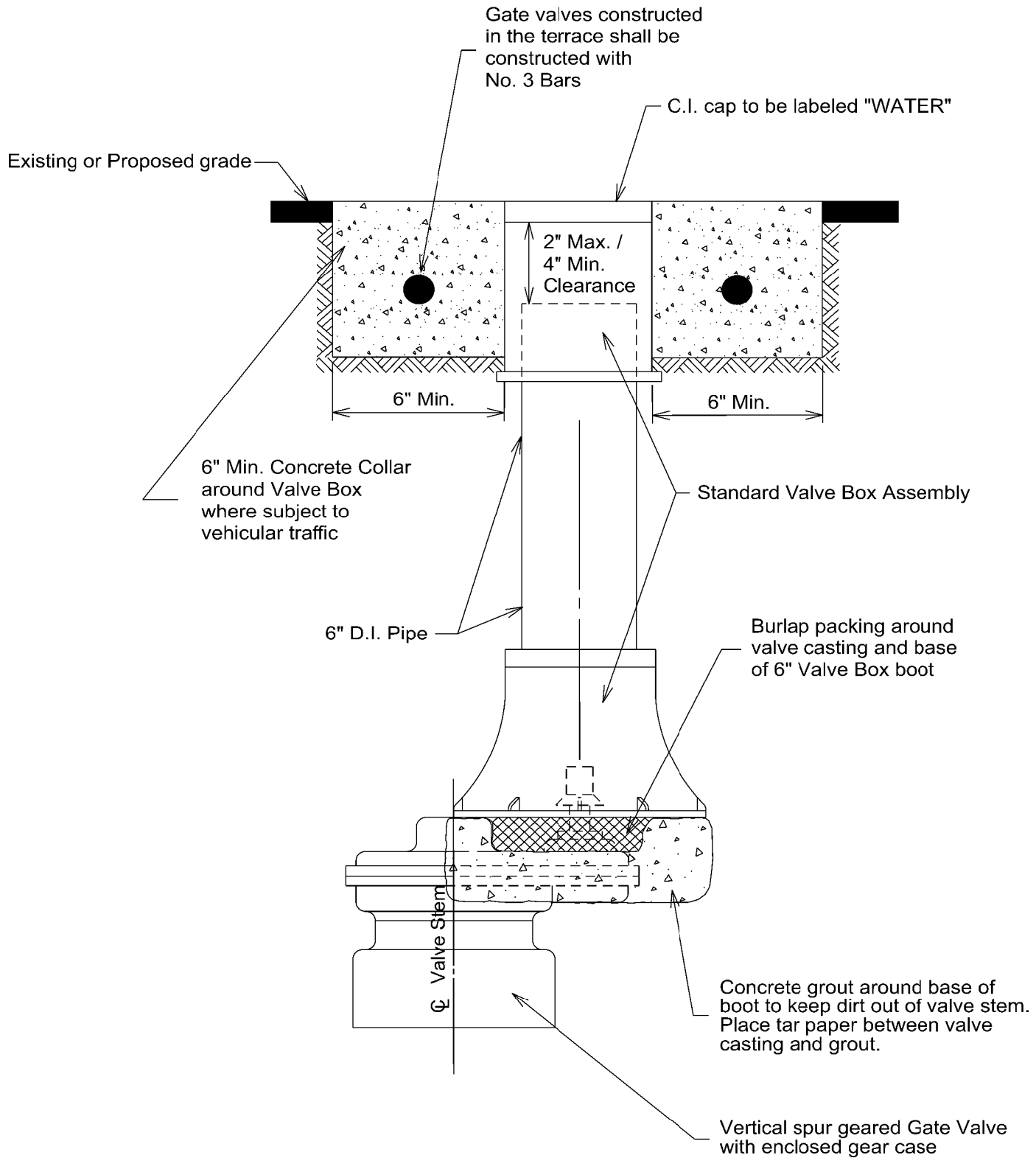

Note: All concrete to be 3,000 psi

PROPERTY OF
SAN ANTONIO WATER SYSTEM
 SAN ANTONIO, TEXAS

**INSTALLATION OF GEARED
 VERTICAL GATE VALVE
 WITH VALVE BOX COMPLETE**

APPROVED
 MARCH 2008

REVISED
 AUG 2019

DD-828-03

SHEET
 1 OF 1

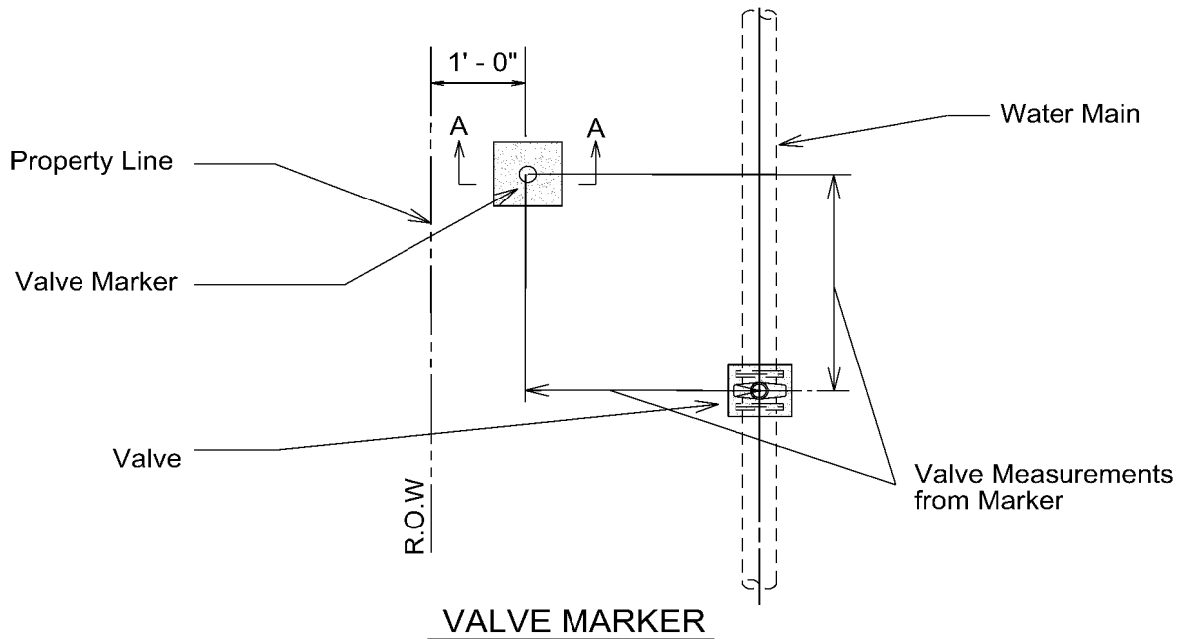

VALVE MARKER

Notes:

1. Valve Marker is 3" Steel pipe painted as shown
2. Valve Measurements shall be referenced to Marker
3. SAWS Decal shall be noted on the marker and facing the direction of the valve.

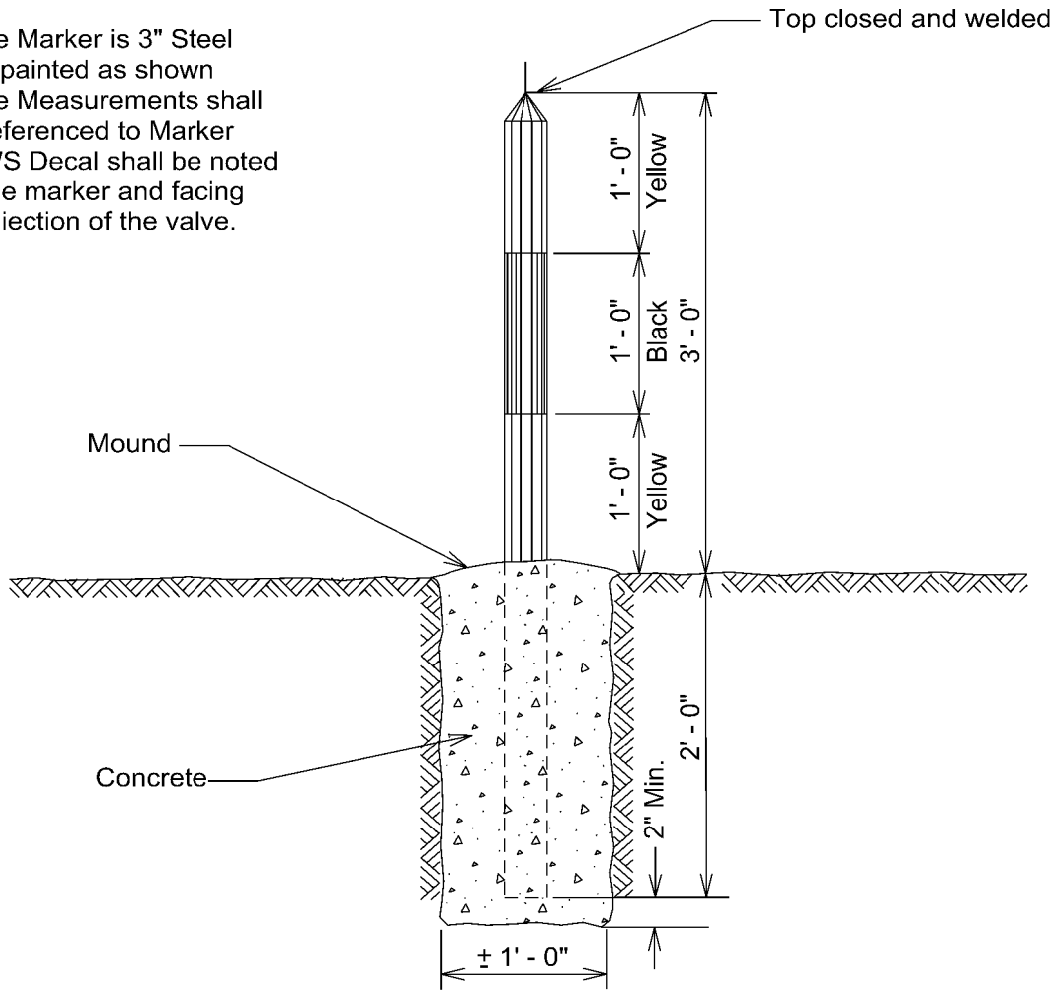

SECTION A-A

San Antonio Water System Standard Specifications for Construction

ITEM NO. 836

Grey Iron and Ductile-Iron Fittings

836.1 DESCRIPTION: This item shall consist of grey-iron and ductile-iron fittings installation and adjustment installed in accordance with these specifications and as directed by the Engineer.

836.2 REFERNCED STANDARDS: Reference standards cited in this Specification Item No. 836 refer to the current reference standard published at the time of the latest revision date.

1. San Antonio Water System (SAWS):
 - a. Specifications for Water and Sanitary Sewer Construction
 - b. SAWS Materials Specifications
2. City of San Antonio (COSA) Standard Specifications for Construction
3. Texas Commission of Environmental Quality (TCEQ) Chapter 290 Public Water Supply
4. American Society for Testing and Materials (ASTM) International:
 - a. ASTM D 1248 – Standard Specification Polyethylene Plastics Molding and Extrusion Materials for Wire and Cable.
 - b. ASTM F 477 – Elastomeric Seals (gaskets) for Joining Plastic Pipe.
 - c. ASTM G 62 – Standard Test Methods for Holiday Detection in Pipeline Coatings.
5. American National Standard Institute (ANSI)
 - a. ANSI A 21.4 (AWWA C 104) – Standard for Cement-Mortar Lining for Ductile-Iron Pipe and Fittings, for Water.
 - b. ANSI A 21.10 (AWWA C 110) – Standard for Ductile-Iron and Gray-Iron Fittings, 3-in. through 48-in.
 - c. ANSI A 21.11 (AWWA C 111) – Standard for Rubber Gasket Joints for Ductile-Iron Pressure Pipe and Fittings.
 - d. ANSI A 21.15 (AWWA C 115) – Standard for Flanged Ductile-Iron Pipe with Ductile-Iron or Gray-Iron Threaded Flanges.
 - e. ANSI A21.16 (AWWA C 116) – Protective Fusion Bonded Epoxy Coating for the Interior and Exterior Surfaces of Ductile Iron and Grey iron Fittings for Water Supply Service.
 - f. ANSI A 21.50 (AWWA C 150) – Standard for Thickness Design of Ductile-Iron Pipe.
 - g. ANSI A 21.51 (AWWA C 151) – Standard for Ductile-Iron Pipe, Centrifugally Cast, for Water and Other Liquids.
 - h. ANSI A 21.53 (AWWA C 153) – Standard for Ductile Iron Compact Fittings, 3 inches through 24 inches and 54 inches through 64 inches for Water Service.
 - i. ANSI/AWS D11.2 –Guide for Welding Iron Castings
6. American Society of Mechanical Engineers (ASME)
 - a. ASME B 16.1 – Cast Iron Pipe Flanges and Flanged Fittings.

San Antonio Water System Standard Specifications for Construction

7. American Water Works Association (AWWA)
 - a. AWWA C 105 – Polyethylene Encasement for Ductile-Iron Pipe Systems.
 - b. AWWA C 300 – Standard for Prestressed Concrete Pressure Pipe, Steel-Cylinder Type, for Water and other Liquids.
 - c. AWWA C 600 – Standard for Installation of Ductile-Iron Water Mains and Their Appurtenances.
8. American Water Works Association (AWWA)
 - a. SSPC-SP 6 – Steel Structures Painting Council, Commercial Blast Cleaning.

836.3 SUBMITTALS: Contractor shall submit manufacturer’s product data, instructions, recommendations, shop drawings, and necessary certifications.

1. For pipes 16 inches and greater submit shop drawings signed and sealed by Professional Engineer registered in State of Texas showing the following:
 - a. Manufacturer’s pipe design calculations.
 - b. Provide lay schedule of pictorial nature indicating alignment and grade, laying dimensions, fitting, flange, and special details, with plan view of each pipe segment sketched, detailing pipe invert elevations, horizontal bends, restrained joints, and other critical features.
 - c. Indicate station numbers for pipe and fittings corresponding to Drawings. Do not start production of pipe and fittings prior to review and approval by Engineer.
 - d. Calculations and limits of thrust restraint shall be based on AWWA M41 or DIPRA Thrust Restraint for Ductile Iron Pipe, latest edition.
 - e. Class and length of joint.
 - f. Submit manufacturer’s certifications that ductile iron pipe and fittings meet provisions of this Section and have been hydrostatically tested at factory and meet requirements of ANSI A 21.51.
 - g. Submit certifications that pipe joints have been tested and meet requirements of ANSI A 21.11.
 - h. Submit affidavit of compliance in accordance with ANSI A21.16 for fittings with fusion bonded epoxy coatings or linings.

836.4 MATERIALS: The materials for grey-iron and ductile-iron fittings installation shall conform to the latest provisions of American National Standard for Ductile-Iron (ANSI)/ American Water Works Association (AWWA) C153/A21.53, Compact Fittings 3-inch through 64-inch and ANSI/AWWA C110/A21.10, Full Body Fittings 3-inch through 48-inch for Water Service or most applicable approved equal provisions, and the specifications contained within the latest revision of SAWS’ Material Specification Item No. 10-10, “Grey-Iron and Ductile-Iron Fittings.”

836.5 CONSTRUCTION: All fittings shall be either restrained mechanical joint compact or flanged joint, unless otherwise specified in the contract documents. All mechanical joint compact fittings shall be installed using approved restraining glands in accordance with SAWS’ Material Specification Item No. 113-02, “Ductile Iron Restrained Joint Fittings for Use on Ductile Iron.”

San Antonio Water System Standard Specifications for Construction

1. No separate payment will be made for these restraining glands.
2. Approved adapters shall be used where necessary to provide a transition between pipes and/or fittings of differing outside diameters.
3. Thrust blocking shall only be utilized, in addition to restraining glands, if specified in the contract documents, when tying into existing non-restrained pipe, or when approved by the Inspector.
4. Anti-corrosion protection consisting of polyethylene sleeve and asphaltic material for ferrous surfaces shall be applied to exterior surfaces of all fittings installed. Anti-corrosion embedment shall be provided as specified in Specification Item No. 804, "Excavation, Trenching and Backfill."

836.6 MEASUREMENT: Ductile-Iron and Grey-Iron Fittings will be measured by their weight as listed in Table 836-1 of this specification of the various sizes of fittings installed.

836.7 PAYMENT: Payment for Grey-Iron and Ductile-Iron Fittings shall be for Mechanical Joint Compact fittings (AWWA) C153/A21.53 and/or flanged fittings.

1. Payment will be made at the unit price bid for each ton of fittings to the nearest one-hundredth of a ton of fittings installed.
2. Individual fitting weights used for payment calculations will be the weights of fittings listed in Table 836-1 of this specification.
3. Weights of glands, bolts, nuts, gaskets (all types) are considered subsidiary to the fittings and no separate payment will be made for their weight.
4. Payment for fitting weights listed in Table 836-1 shall be full compensation for excavation, installation, anti-corrosion protection, select anti-corrosion embedment material and installation, hauling and disposition of surplus excavated materials, all glands, bolts, nuts, rubbers, and flange gaskets of whatever type required, and concrete thrust/reaction blocking, if required.
5. If fittings other than those listed in Table 836-1 are approved and installed, the Contractor shall provide quantities and manufacturers unit weights exclusive of glands, bolts, and rubbers with pay request.
6. Materials paid on site will be in accordance with Table 1 of Specification Item No. 100 Mobilization.

San Antonio Water System Standard Specifications for Construction

TABLE 836-1							
WEIGHTS OF GREY-IRON AND DUCTILE-IRON FITTINGS (LBS.)							
BENDS							
Size (Inches)	MJ Compact (C153)	MJ (C110)	FLG SB	Size (Inches)	MJ Compact (C153)	MJ (C110)	FLG SB
1/4 Bend (90 Degrees)				1/8 Bend (45 degrees)			
4	25	55	44	4	21	51	36
6	43	86	67	6	35	75	57
8	61	125	115	8	50	110	105
12	119	258	236	12	96	216	196
16	264	454	478	16	200	345	315
20	447	716	878	20	337	555	485
24	602	1105	1085	24	441	777	730
30	979	1740	1755	30	775	1393	1355
36	1501	2507	2135	36	1140	2163	1755
42	2277	3410	3055	42	1652	2955	2600
48	3016	4595	4095	48	2157	4080	3580
BENDS							
Size (Inches)	MJ Compact (C153)	MJ (C110)	FLG SB	Size (Inches)	MJ Compact (C153)	MJ (C110)	FLG SB
1/16 Bend (22-1/2 Degrees)				1/32 Bend (11-1/4 degrees)			
4	18	50	35	4	17	50	40
6	32	75	64	6	30	73	56
8	46	110	90	8	42	109	90
12	85	220	194	12	74	220	193
16	175	354	315	16	153	354	315
20	314	550	505	20	265	553	505
24	414	809	528	24	339	815	760
30	668	1500	1385	30	603	1410	1395
36	963	2182	1790	36	830	2195	1805
42	1354	3020	2665	42	1210	3035	2680
48	1790	4170	3665	48	1523	4190	3695

San Antonio Water System Standard Specifications for Construction

TABLE 836-1 CONTINUATION				
WEIGHTS OF GREY-IRON AND DUCTILE-IRON FITTINGS (LBS.)				
TEES				
Size (Inches)		Weight		
Run	Branch	MJ Compact (C153)	MJ (C110)	FLG Short Body
3	3	26	56	53
4	3	31	76	54
	4	33	80	60
6	4	49	114	90
	6	60	124	98
8	4	65	163	155
	6	76	175	148
	8	89	188	179
12	4	99	316	322
	6	115	325	297
	8	127	339	346
	12	162	407	369
16	6	226	563	573
	8	240	565	555
	12	283	615	590
	16	326	676	635
20	6	344	750	773
	8	371	766	720
	12	427	799	816
	16	503	975	950
	20	566	1068	1005

TABLE 836-1 CONTINUATION				
WEIGHTS OF GREY-IRON AND DUCTILE-IRON FITTINGS (LBS.)				
TEES				
Size (Inches)		Weight		
Run	Branch	MJ Compact (C153)	MJ (C110)	FLG Short Body
24	6	466	1035	1089
	8	487	1047	1060
	12	539	1075	1125
	16	625	1109	1070
	20	729	1504	1510
	24	785	1617	1685
30	8	739	1808	-
	12	800	1842	1801
	16	959	1885	-
	20	1026	1941	-
	24	1228	2496	2475
	30	1373	2531	2615
36	24	1548	2710	2255
	30	1901	3545	3000
	36	2012	3686	3160
42	24	2272	3690	3245
	30	2512	4650	4125
	36	3048	5119	5360
	42	3225	6320	5580
48	24	2934	4995	4385
	30	3147	5140	4455
	36	4046	6280	5555
	42	4249	8130	7195

San Antonio Water System Standard Specifications for Construction

TABLE 836-1 CONTINUATION				
WEIGHTS OF GREY-IRON AND DUCTILE-IRON FITTINGS (LBS.)				
CROSSES				
Size (Inches)		Weight		
Run	Branch	MJ Compact (C153)	MJ (C110)	FLG Short Body
24	6	566	1025	-
	8	578	1085	1045
	12	610	1153	1110
	16	663	1256	1200
	20	975	1733	1675
	24	907	1906	1835
30	8	650	1795	-
	12	870	1925	1865
	16	900	1950	-
	20	1220	2060	-
	24	1497	2776	2675
	30	1808	3188	3075
36	24	1853	2928	2980
	30	2580	3965	-
	36	2698	4370	4370
42	24	2415	3910	-
	30	2920	5040	-
	36	3788	5835	-
	42	3908	6493	7145
48	24	3435	5210	-
	30	4145	5495	-
	36	4873	6790	-
	42	5465	8815	-
	48	5588	9380	-

San Antonio Water System Standard Specifications for Construction

TABLE 836-1 CONTINUATION				
WEIGHTS OF GREY-IRON AND DUCTILE-IRON FITTINGS (LBS.)				
CAPS			PLUGS	
Size (Inches)	MJ Compact (C153)	MJ (C110)	MJ Compact (C153)	MJ (C110)
4	10	17	12	16
6	16	29	19	28
8	24	45	30	46
12	45	82	54	85
16	95	160	97	146
20	141	235	146	218
24	193	346	197	350
30	362	644	381	626
36	627	912	688	884
42	893	1322	1200	1222
48	1076	1737	1550	1597

TABLE 836-1 CONTINUATION				
WEIGHTS OF GREY-IRON AND DUCTILE-IRON FITTINGS (LBS.)				
SOLID SLEEVES				
Size (Inches)	Weight			
	MJ Short Compact (C153)	MJ Long Compact (C153)	MJ Short (C110)	MJ Long (C110)
4	17	21	35	46
6	28	35	45	65
8	38	48	65	86
12	57	77	113	143
16	127	172	192	257
20	201	258	258	359
24	264	337	340	474
30	500	651	690	1005
36	725	960	947	1374
42	877	1209	1187	1628
48	1406	1516	1472	2033

San Antonio Water System Standard Specifications for Construction

TABLE 836-1 CONTINUATION			
WEIGHTS OF GREY-IRON AND DUCTILE-IRON FITTINGS (LBS.)			
CONCENTRIC REDUCERS			
Size (Inches)			Weight
Large End	Small End	MJ Compact (C153)	MJ (C110)
6	4	27	59
8	4	38	81
8	6	41	95
12	4	70	136
12	6	69	150
12	8	70	167
16	6	134	234
16	8	136	258
16	12	126	310
20	12	213	427
20	16	221	492
24	12	304	562
24	16	315	633
24	20	315	727
30	16	596	1027
30	20	599	1085
30	24	492	1204
36	20	1042	1459
36	24	785	1580
36	30	655	1868
42	24	1356	2060
42	30	1112	2370
42	36	1116	2695
48	30	1722	3005
48	36	1650	3370
48	42	1429	3750

San Antonio Water System Standard Specifications for Construction

TABLE 836-1 CONTINUATION		
WEIGHTS OF GREY-IRON AND DUCTILE-IRON FITTINGS (LBS.)		
2" Tapped Tees and Crosses		
Size (Inches)	Weight	
	MJ Compact (C153)	MJ (C110)
4	24	47
6	36	71
8	54	97
10	69	130
12	87	169
20	-	259
24	-	320

TABLE 836-1 CONTINUATION		
WEIGHTS OF GREY-IRON AND DUCTILE-IRON FITTINGS (LBS.)		
OFFSETS		
Size (Inches)	Weight	
	MJ Compact (C153)	MJ (C110)
4 x 6	35	75
4 x 12	55	83
6 x 6	35	110
6 x 12	67	138
6 x 24	96	189
8 x 6	82	164
8 x 12	98	209
8 x 24	141	280
12 x 6	121	320
12 x 12	178	420
12 x 24	240	645
20 x 12	-	1025
20 x 24	-	1245

-End of Specifications-

San Antonio Water System Standard Specifications for Construction

ITEM NO. 839

Anchorage/Thrust Blocking and Joint Restraint

839.1 DESCRIPTION: This item shall consist of anchorage/thrust blocking and joint restraint installation in accordance with these specifications and as directed by the Engineer or Manufacturer's recommendations.

839.2 REFERENCED STANDARDS: Reference standards cited in this Specification Item No. 839 refer to the current reference standard published at the time of the latest revision date.

1. San Antonio Water System (SAWS):
 - a. Specifications for Water and Sanitary Sewer Construction
 - b. SAWS Materials Specifications
2. City of San Antonio (COSA) Standard Specifications for Construction

839.3 MATERIALS: The materials for anchorage/thrust blocking installation shall conform to the appropriate specifications contained within the latest revision of SAWS Material Specifications.

1. Pipe restraint devices shall conform to the latest revision of SAWS' Material Specification Item No. 95-10, "Specifications of Pipe Joint Restraint Systems," and Item No. 113-02, "Ductile Iron Restrained Joint Fittings for Use on Ductile Iron."

839.4 CONSTRUCTION: Suitable anchorage/thrust blocking or joint restraint shall be provided at all of the following main locations: dead ends, plugs, caps, tees, crosses, valves, and bends, in accordance with the Standard Drawings DD-839 Drawing Series.

1. All mechanical (joint) restraints shall be bidirectional.
2. Anchor blocks shall be constructed solidly behind the fitting and symmetrical with the axis of resultant thrust, except where this is not possible as in the case of gravity anchorage for vertical bends.
3. If the restraint limits do not fall on a joint, restraint shall be moved to next further joint.
4. Cutting of pipe to install joint restraints is not permitted.
5. Special ties and anchor fittings may be utilized in conjunction with blocking when shown in the contract documents or as directed by Engineer or Inspector.
6. All thrust blocking shall be a minimum of 3,000 psi concrete placed between solid ground and the fitting except as otherwise shown in the contract documents.
7. The area of bearing in contact with solid ground shall be that as shown in the contract documents or as directed by the Engineer.
8. All thrust blocking placed in conjunction with mains and appurtenances shall be in accordance with Standard Drawings DD-839 Series.
9. In all cases, the design of thrust blocking shall be of sufficient size to withstand an assumed soil lateral load bearing capacity of 3,000 psf, unless specified otherwise in the contract documents.

San Antonio Water System Standard Specifications for Construction

10. When specifically requested by the Contractor and approved by the Engineer, the maximum soil lateral load bearing capacity that will be allowed for the design of thrust blocking shall be 5,000 psf.
11. When soil lateral load bearing capacities of 4,000 psf or 5,000 psf are recorded for design of thrust blocks, copies of soil tests made for determining the lateral load bearing capacity of the subject soil shall be submitted to the Engineer for approval.
12. The blocking shall be placed so that pipe and fitting joints will be accessible.
13. Pipe restraint devices shall be installed according to the lengths prescribed herein, recommended by pipe manufacturer, or as noted in the contract documents, whichever is more restrictive.
14. Pipe polywrap shall be placed between the pipe or fitting and the concrete.
15. The reaction block on the unused branch of a fitting shall be poured separately from the block across the back of the fitting. If they are poured simultaneously, a rigid partition shall be placed between the blocks.
16. Valves 12 inches or larger in size shall be supported on a concrete pad extending vertically from 12 inches below the bottom of the valve to the lower quarter point of the hub and laterally from face to face of hubs and transversely from wall to wall of the trench.
17. All joints for carrier pipe installed within casing shall be restrained.

839.5 MEASUREMENT: Anchorage/Thrust Blocking or Joint Restraints are considered subsidiary to the work and no separate payment will be made to the Contractor for this work.

839.6 PAYMENT: Anchorage/Thrust Blocking or Joint Restraints are considered subsidiary to the work and no separate payment will be made to the Contractor for this work.

-End of Specification-

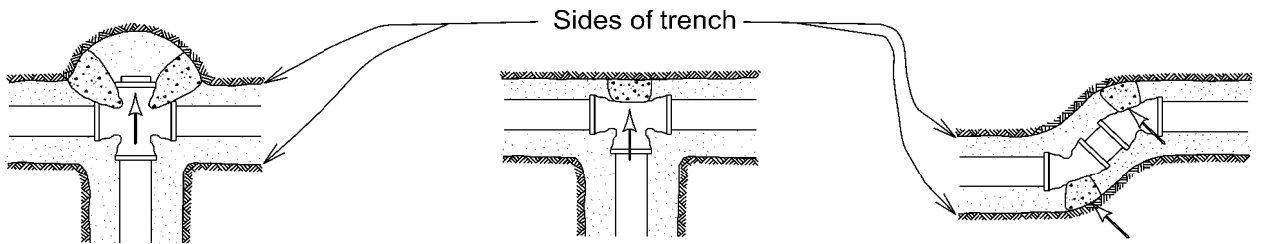

Sides of trench

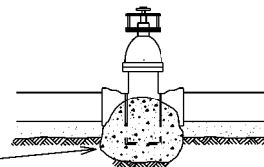
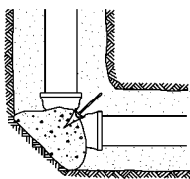
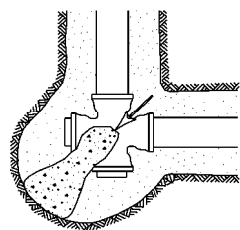
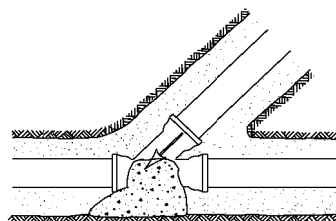
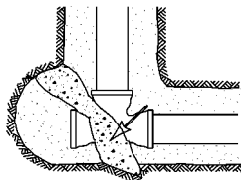
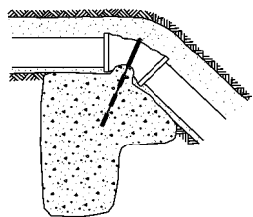

Concrete blocking required for all 12" & larger, except in high pressure distribution system where blocking is required for all valves

Select Material

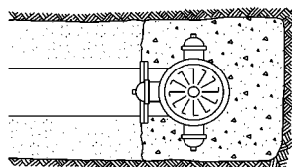

PLAN

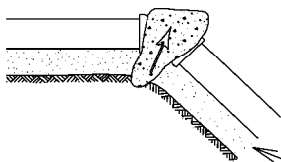

Select Material

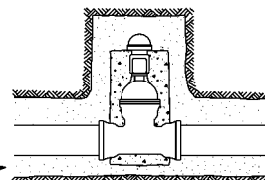

PLAN

Pour base after Hydrant has been placed

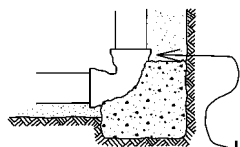

ELEVATION

Hydrant Drain

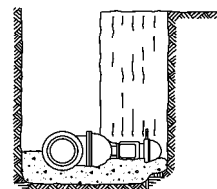
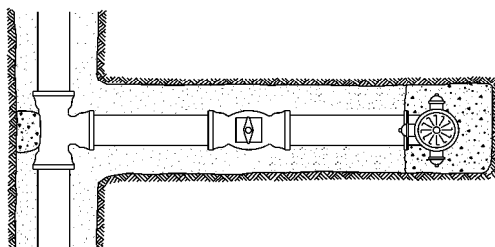

ELEVATION

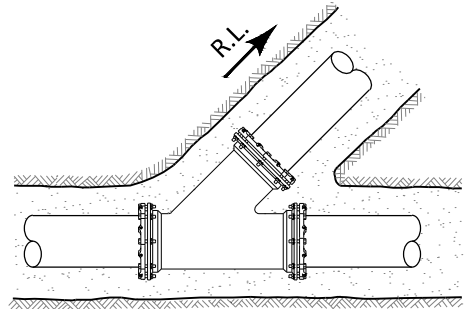
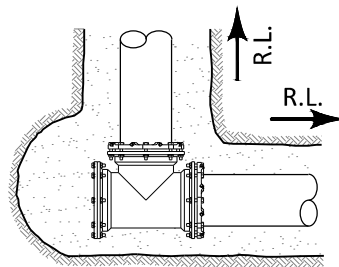
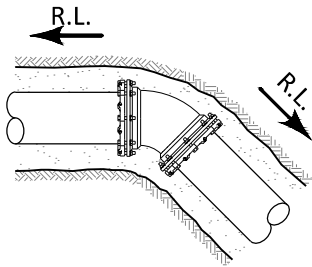
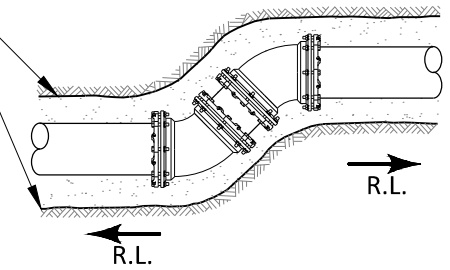
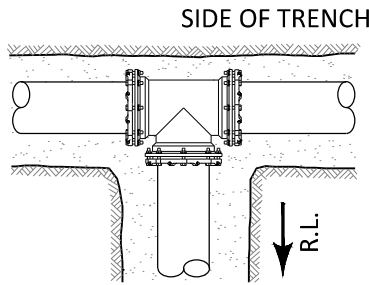
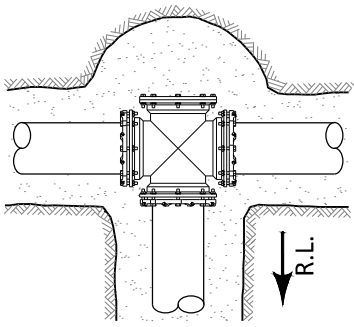

R.L. = RESTRAINED LENGTHS TO BE DETERMINED BY DESIGN ENGINEER

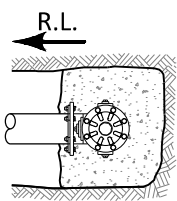
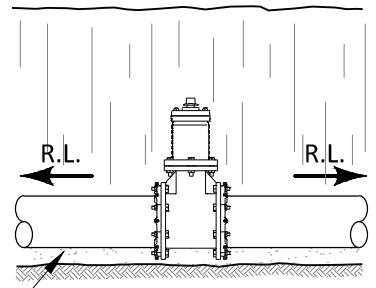
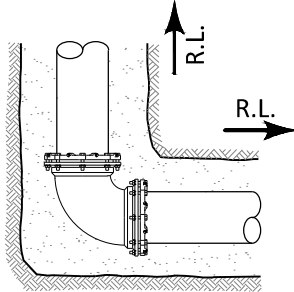
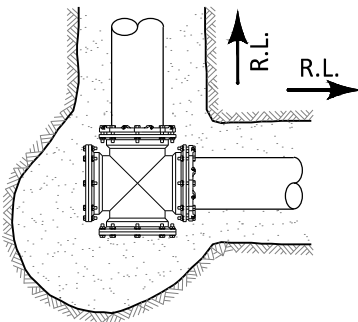

PLAN

POUR CONCRETE AFTER HYDRANT HAS BEEN PLACED

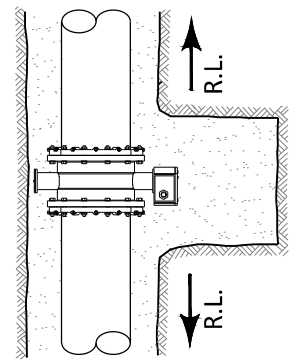
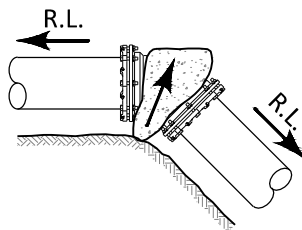

PLAN

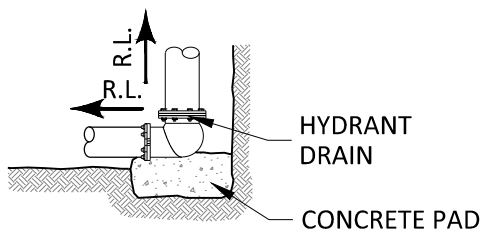

ELEVATION

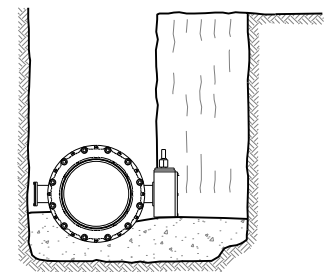
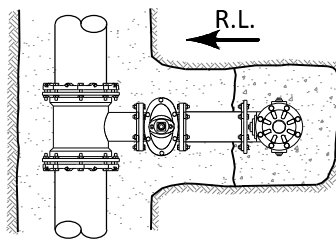

ELEVATION

Typical blocking for 90° Bend

Area in Sq. Ft. for each of the following pipe sizes

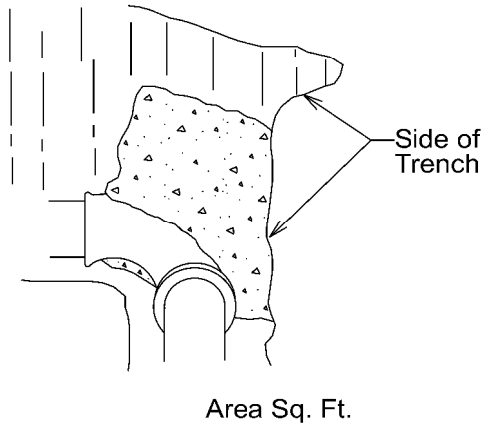

THRUST BLOCKING DESIGN

On basis of 200 psi water pressure used for tests, the blocking required for two types of soils are noted below. In one case, a soil pressure of 5000 psf is used for rock excavation and for soils other than rock a 3000 psf bearing soil pressure is used. The distribution on system is pressure of 175 psf all calculations apply to A.C. Pipe Class 200 and Ductile Iron Pipe Class 2. PVC Pipe Class 200 (SDR 13.5)

2 Sq. Ft. in rock & 4 Sq. Ft. in other soils

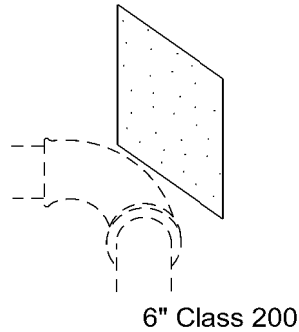

Area Sq. Ft.

4 Sq. Ft. in rock & 6 Sq. Ft. in other soils

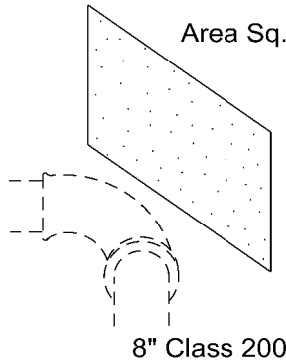

Area Sq. Ft.

9 Sq. Ft. in rock & 14 Sq. Ft. in other soils

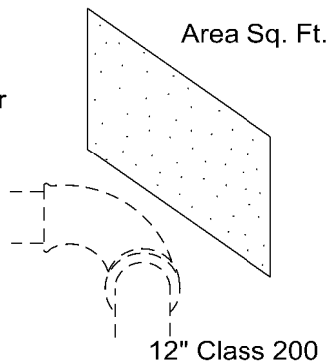

Area Sq. Ft.

Blocking area for 200 psi tests & 175 psi working pressures.

Square feet of blocking required for rock excavation

SIZE PIPE	TEES & DEAD ENDS	90° BENDS	45° BENDS	22 1/2° BENDS
6"	2	2	1	1
8"	3	4	2	1
12"	6	9	5	2
16"	11	15	8	4

Square feet of blocking required for other than rock excavation

SIZE PIPE	TEES & DEAD ENDS	90° BENDS	45° BENDS	22 1/2° BENDS
6"	3	4	2	1
8"	4	6	4	2
12"	10	14	8	4
16"	18	25	14	7

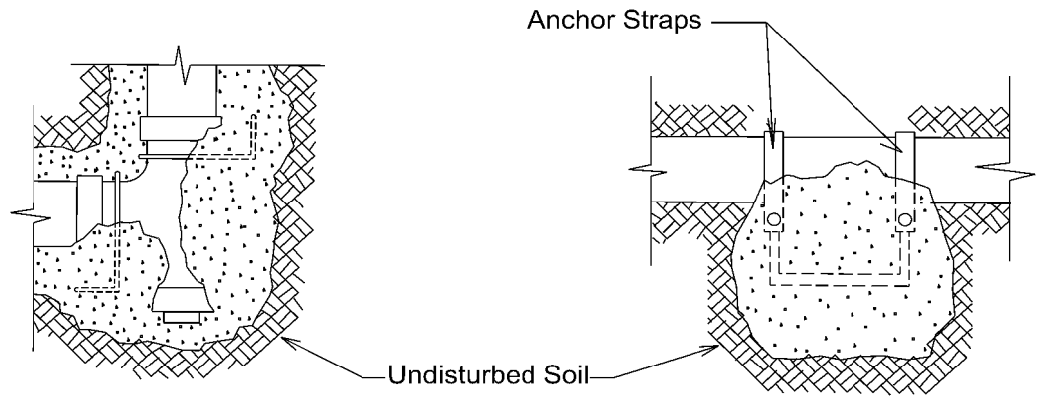
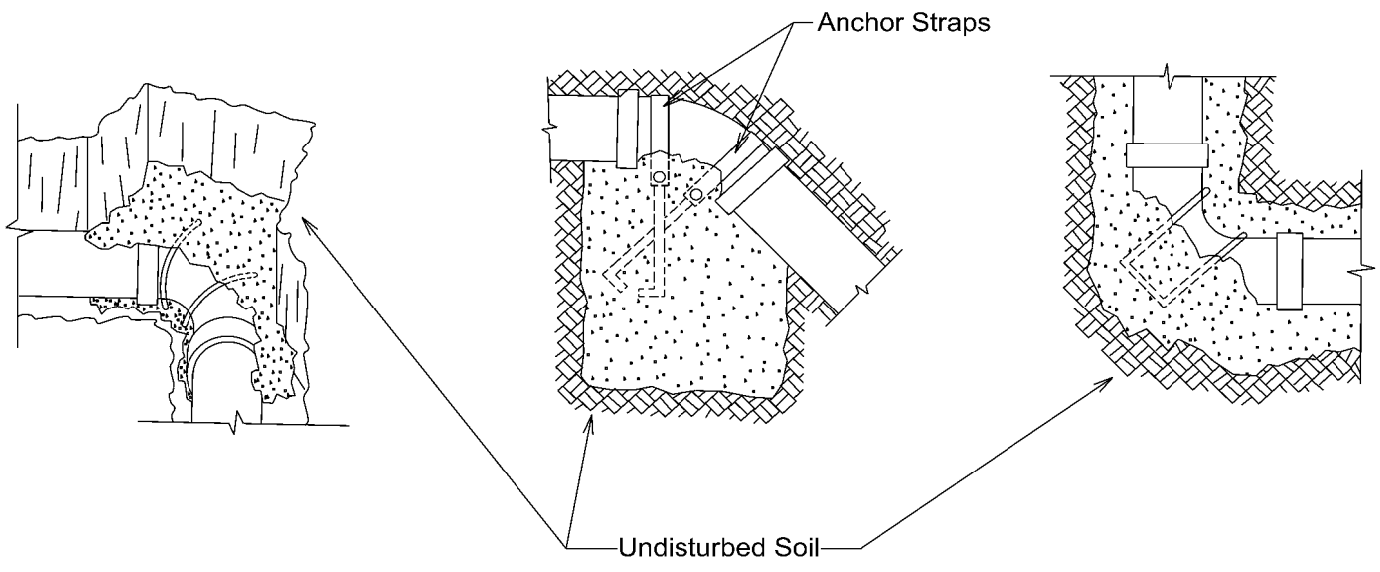

Note:
 All concrete used for thrust blocking shall have a minimum concrete strength of 3,000 psi

PROPERTY OF SAN ANTONIO WATER SYSTEM SAN ANTONIO, TEXAS	TYPICAL THRUST BLOCKS (SEWER ONLY)	APPROVED	REVISED
		March 2008	AUG 2019
		DD-839-03	

RESTRAINED LENGTH FOR TEES (Cont'd)

PIPE SIZE (inch)	BRANCH SIZE (inch)	LENGTH OF RUN (ft.)	RESTRAINED LENGTH IN FEET, WHEN TEST PRESSURE = 200 psi	RESTRAINED LENGTH IN FEET, WHEN TEST PRESSURE = 150 psi
12	4	0	42	31
12	4	5	1	1
12	6	0	59	44
12	6	5	13	1
12	6	10	1	1
12	8	0	77	58
12	8	5	42	23
12	8	10	7	1
12	8	15	1	1
12	12	0	109	82
12	12	5	86	59
12	12	10	63	35
12	12	15	39	12

RESTRAINED LENGTH DESIGN

Restrained length calculations are for P.V.C pipe bedded in compacted granular material extending to the top of the pipe. The native soil material is assumed to be inorganic clay of high plasticity. Depth of bury is assumed to be 4 feet.

Note:

These calculations are provided for reference. The restrained length shall be designed based upon the conditions encountered during the installation.

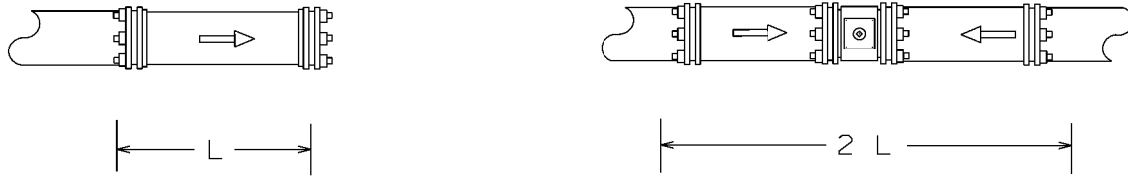

L=LENGTH TO BE RESTRAINED

PIPE SIZE (inch)	RESTRAINED LENGTH IN FEET, WHEN TEST PRESSURE = 200 psi	RESTRAINED LENGTH IN FEET, WHEN TEST PRESSURE = 150 psi
6	59	44
8	77	58
10	93	69
12	109	82

RESTRAINED LENGTH DESIGN

Restrained length calculations are for P.V.C. pipe bedded in compacted granular material extending to the top of the pipe. The native soil material is assumed to be inorganic clay of high plasticity. Depth of bury is assumed to be 4 feet.

Note:

These calculations are provide for reference. The restrained length shall be designed based upon the conditions encountered during the installation.

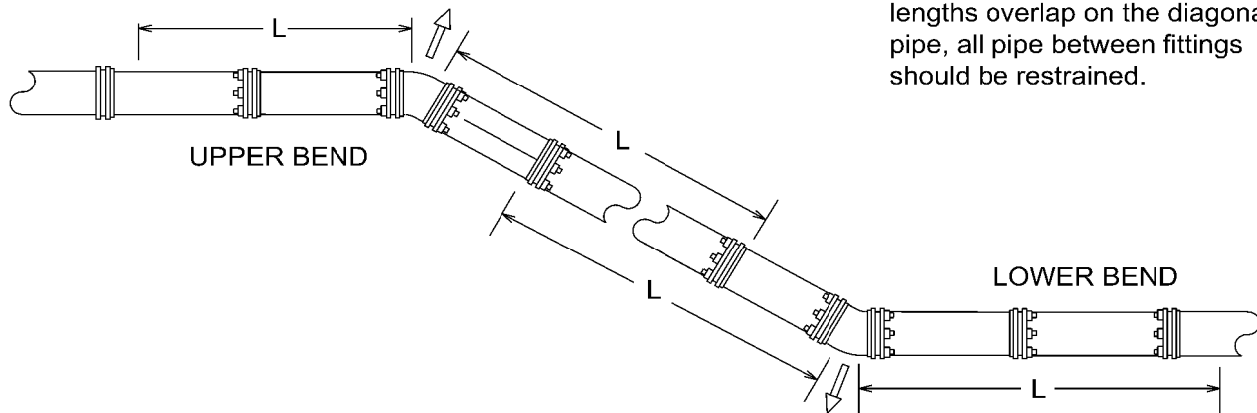

L = Length to be restrained on both sides of fitting. When restrained lengths overlap on the diagonal pipe, all pipe between fittings should be restrained.

PIPE SIZE (inch)	BEND ANGLE (deg.)	LOW SIDE DEPTH	UPPER BEND RESTRAINED LENGTH IN FEET TEST PRESSURE = 200 psi	LOWER BEND RESTRAINED LENGTH IN FEET TEST PRESSURE = 200psi	UPPER BEND RESTRAINED LENGTH IN FEET TEST PRESSURE = 150 psi	LOWER BEND RESTRAINED LENGTH IN FEET TEST PRESSURE = 150 psi
6	45	5	24	8	18	6
6	22.5	5	12	4	9	3
6	11.25	5	6	2	4	1
6	45	10	24	5	18	4
6	22.5	10	12	2	9	2
6	11.25	10	6	1	4	1
8	45	5	32	11	24	8
8	22.5	5	15	5	11	4
8	11.25	5	8	3	6	2
8	45	10	32	7	24	5
8	22.5	10	15	3	11	2
8	11.25	10	8	2	6	1
12	45	5	45	16	34	12
12	22.5	5	22	7	16	6
12	11.25	5	11	4	8	3
12	45	10	45	10	34	7
12	22.5	10	22	5	16	3
12	11.25	10	11	2	8	2

RESTRAINED LENGTH DESIGN

Restrained length calculations are for P.V.C. pipe bedded in compacted granular material extending to the top of the pipe. The native soil material is assumed to be inorganic clay of high plasticity. Depth of bury is assumed to be 4 feet.

Note:

These calculations are provided for reference. The restrained length shall be designed based upon the conditions encountered during the installation.

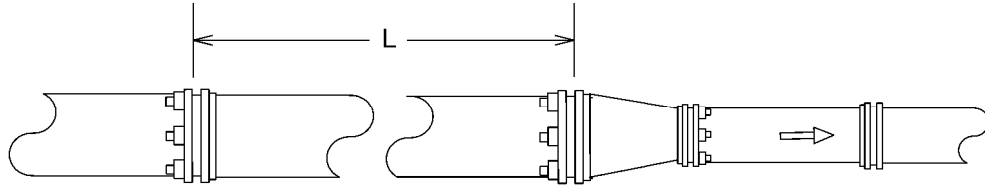

L=Length to be restrained

PIPE SIZE (inch)	SMALL SIZE (inch)	RESTRAINED LENGTH IN FEET, WHEN TEST PRESSURE = 200 psi	RESTRAINED LENGTH IN FEET, WHEN TEST PRESSURE = 150 psi
6	4	30	23
8	4	55	42
8	6	32	24
12	4	95	71
12	6	80	60
12	8	58	43

RESTRAINED LENGTH DESIGN

Restrained length calculations are for P.V.C. pipe bedded in compacted granular material extending to the top of the pipe. The native soil material is assumed to be inorganic clay of high plasticity. Depth of bury is assumed to be 4 feet.

Note:

These calculations are provided for reference. Th restrained length shall be designed based upon the conditions encountered during the installation.

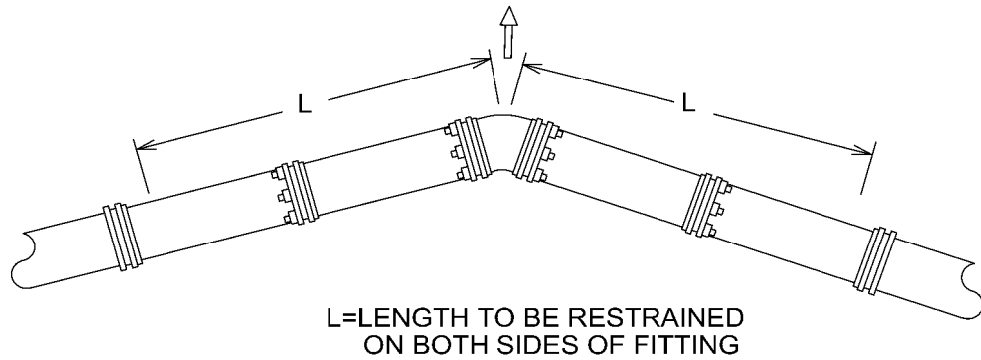

PIPE SIZE (inch)	BEND ANGLE (deg)	RESTRAINED LENGTH IN FEET, WHEN TEST PRESSURE = 200 psi	RESTRAINED LENGTH IN FEET, WHEN TEST PRESSURE = 150 psi
6	90	23	17
6	45	9	7
6	22.5	5	3
6	11.25	2	2
8	90	30	22
8	45	12	9
8	22.5	6	4
8	11.25	3	2
12	90	43	32
12	45	18	13
12	22.5	8	6
12	11.25	4	3

RESTRAINED LENGTH DESIGN

Restrained length calculations are for P.V.C pipe bedded in compacted granular material extending to the top of the pipe. The native soil material is assumed to be inorganic clay of high plasticity. Depth of bury is assumed to be 4 feet.

Note:

These calculations are provided for reference. The restrained length shall be designed based upon the conditions encountered during the installation.

San Antonio Water System Standard Specifications for Construction

ITEM NO. 844

Temporary and Permanent Blow-off Assemblies

844.1 DESCRIPTION: This item shall consist of blow-off assemblies installed in accordance with these specifications and as directed by the Engineer.

844.2 REFERENCED STANDARDS: Reference standards cited in this Specification Item No. 844 refer to the current reference standard published at the time of the latest revision date.

1. San Antonio Water System (SAWS):
 - a. Specifications for Water and Sanitary Sewer Construction
 - b. SAWS Materials Specifications
2. City of San Antonio (COSA) Standard Specification for Construction
3. Texas Commission of Environmental Quality (TCEQ)
 - a. Chapter 210 Use of Reclaim Water
 - b. Chapter 290 Rules and Regulations for Public Regulations for Public Water Systems
 - c. Chapter 213 Edwards Aquifer.
4. American National Standard Institute
 - a. ANSI A 21.11/AWWA C111 - Standard for Rubber-Gasket Joints for Ductile-Iron Pressure Pipe and Fittings.
5. ANSI/NSF Standard 61 - Drinking Water System - Health Components. American Society for Testing and Materials (ASTM) International:
Pressure Pipe and Fittings.
 - a. ASTM A 36 - Standard Specification for Carbon Structural Steel.
 - b. ASTM A 536 - Standard Specification for Ductile Iron Castings.
 - c. ASTM A 126 - Standard Specification for Gray Iron Castings for Valves, Flanges, and Pipe Fittings.
 - d. ASTM B 21 - Standard Specification for Naval Brass Rod, Bar, and Shapes.
 - e. ASTM B 98 - Standard Specification for Copper-Silicon Alloy Rod, Bar, and Shapes.
 - f. ASTM B 301 - Standard Specification for Free-Cutting Copper Rod and Bar.
 - g. ASTM B 584 - Standard Specification for Copper Alloy Sand Casting for General Application.
 - h. ASTM E 165 - Standard Test Method for Liquid Penetrant Examination.
 - i. ASTM E 709 - Standard Guide for Magnetic Particle Examination.
 - j. ASTM F 1674 - Standard Test Method for Joint Restraint Products for Use with PVC Pipe.
6. American Water Works Association (AWWA)

San Antonio Water System Standard Specifications for Construction

- a. AWWA C 207 - Standard for Steel Pipe Flanges for Waterworks Service - Sizes 4 Inches through 144 Inches

844.3 SUBMITTALS: Contractor shall submit manufacturer's product data, instructions, recommendations, shop drawing, and certifications. All submittals shall be in accordance with Engineer's requirements and submittals shall be approved prior to delivery.

844.4 MATERIALS: The materials for blow-off assemblies, installation and adjustment shall conform to the specifications contained within the latest revision of SAWS' Material Specification.

844.5 CONSTRUCTION: Permanent and temporary blow-off assemblies shall be installed where shown on the plans and/or at locations designated by the Engineer and at the end of the all dead end mains in accordance with the Texas Administrative Code (TAC) rules to include 30 TAC § 290.44.(d)(5), (6).

1. The permanent blow-off shall consist of all HDPE, valve, and fittings of the various sizes shown on the plans, six (6) inch valve box assembly and concrete collar around the valve box.
2. The temporary blow-off shall consist of all, DI or HDPE, valve and fittings of the various sizes shown on the plans.
3. Valve box shall be raised or installed to finished grade and installed in accordance with Standard Drawing DD-844 Series.

844.6 MEASUREMENT:

1. Permanent Blow-off assemblies will be measured by the required unit of each such assembly of the various sizes of permanent blow-offs installed.
2. Temporary Blow-off assemblies will be measured by the required unit of each such assembly of the various sizes of temporary blow-offs installed.

844.7 PAYMENT: Payment for Permanent and Temporary Blow-off Assemblies will be made at the unit price bid for each such required assembly of the various types and sizes installed in accordance with the details shown in the Standard Drawing DD-844 Series.

1. **844.7.1** Payment for Permanent Blow-Off Assembly shall include excavation, selected embedment material, anti-corrosion embedment when specified, and the hauling and disposition of surplus excavated materials, compaction, compaction testing, blocking, accessories and appurtenances, hauling and disposition of surplus excavated material, including all existing pipe, fittings, appurtenances to be abandoned or removed, surface and pavement restoration, installation of all-weather surface, and other required testing.
2. **844.7.2** Payment for Temporary Blow-Off Assembly shall include excavation, selected embedment material, anti-corrosion embedment when specified, removal of Temporary Blow-off assembly and the hauling and disposition of surplus

San Antonio Water System Standard Specifications for Construction

excavated materials, compaction, compaction testing, blocking, accessories and appurtenances, hauling and disposition of surplus excavated material, including all existing pipe, fittings, appurtenances to be abandoned or removed, surface and pavement restoration, installation of all-weather surface, and other required testing.

3. Materials paid on site will be in accordance with Table 1 of Specification Item No. 100 Mobilization.
4. Payment for eccentric reducers and eccentrically tapped caps and flanges will be made under Specification Item No. 836, "Cast-Iron Fittings,"
5. Payment for the pipe nipple with reaction stop ring will be made under Specification Item No. 812, "Water Main Installation."

-End of Specification-

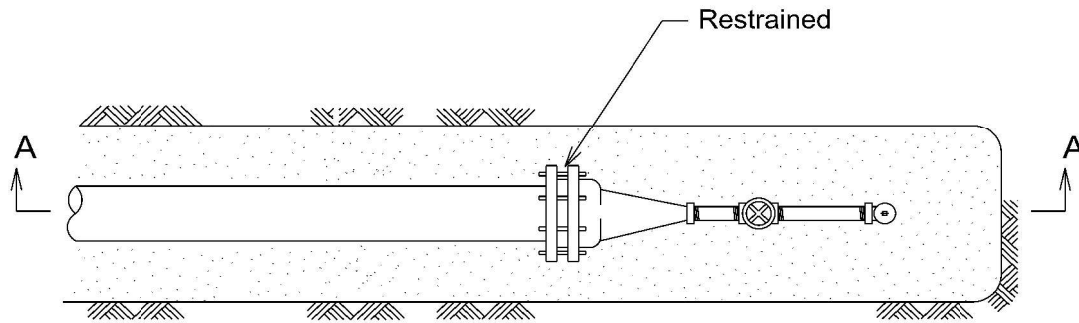

PLAN

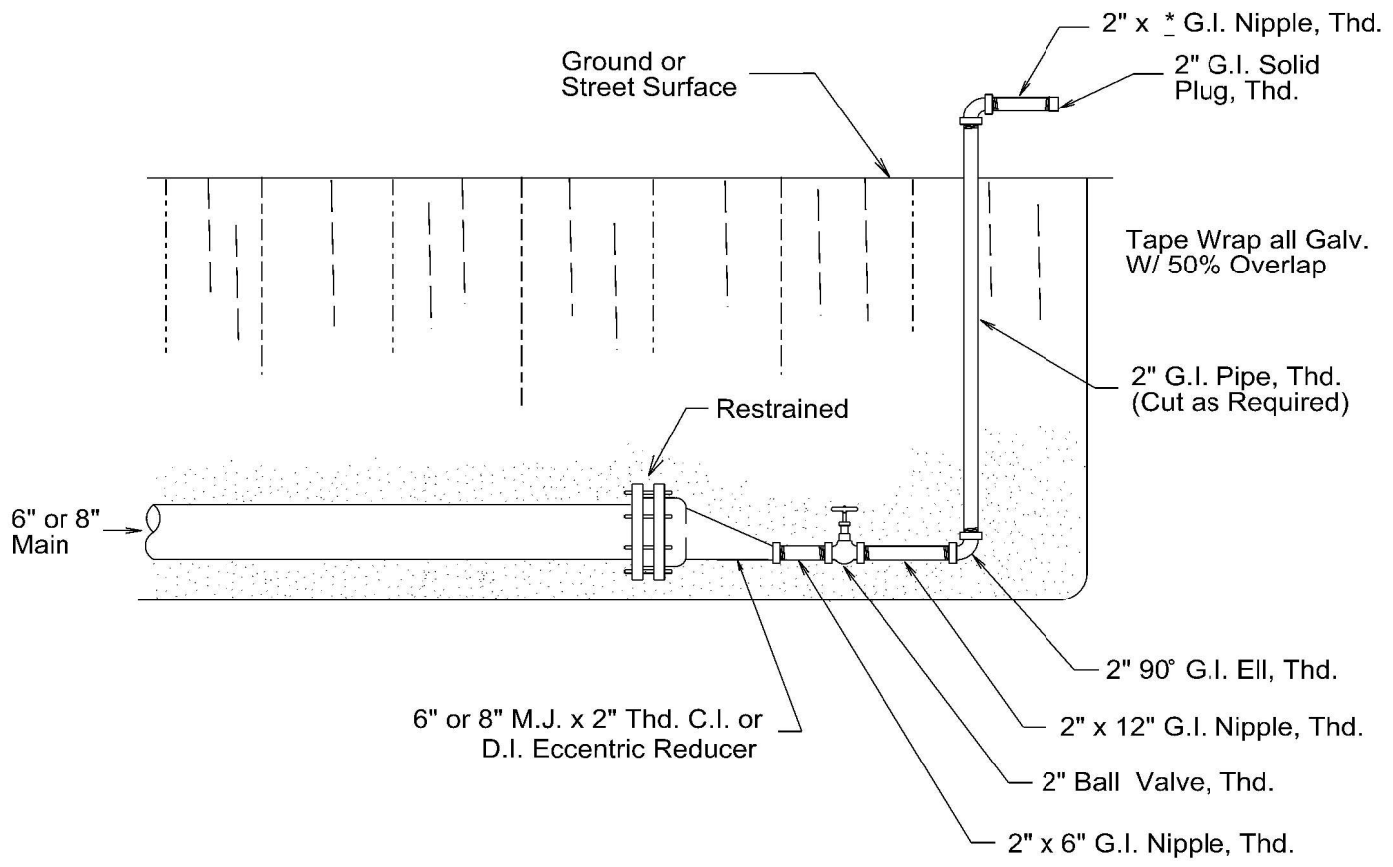

SECTION A-A

* Cut as required to extend beyond excavation

PROPERTY OF SAN ANTONIO WATER SYSTEM SAN ANTONIO, TEXAS	2" TEMPORARY BLOW-OFF ASSEMBLY ON 6" & 8" MAINS	APPROVED	REVISED
		MARCH 2008	AUG 2019
		DD-844-01	SHEET 1 OF 4

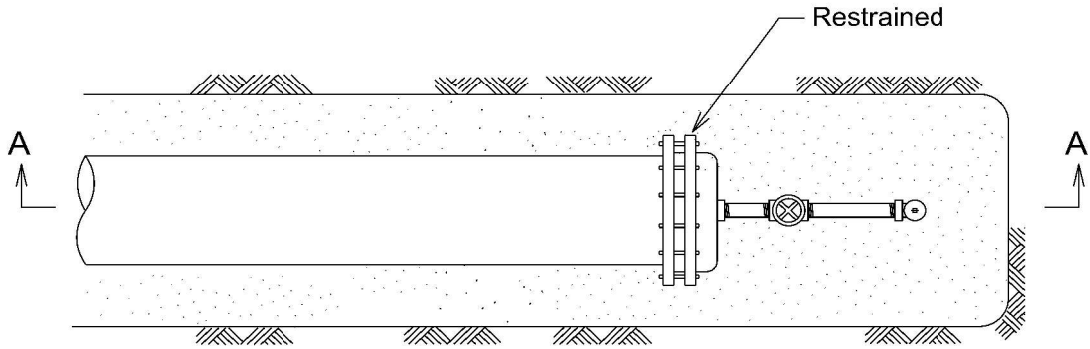

PLAN

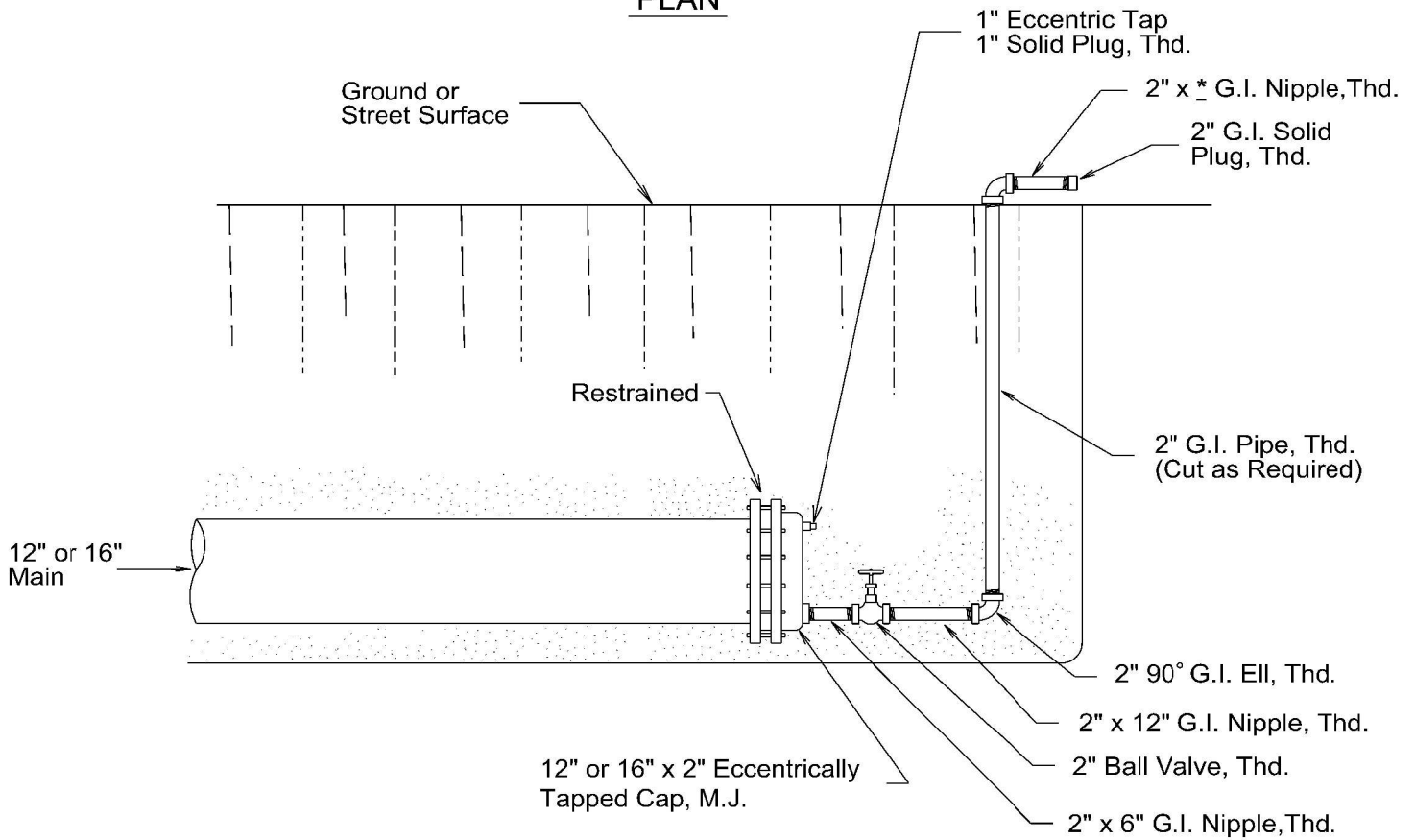

SECTION A-A

* Cut as required to extend beyond excavation.

PROPERTY OF SAN ANTONIO WATER SYSTEM SAN ANTONIO, TEXAS	2" TEMPORARY BLOW-OFF ASSEMBLY ON 12" & 16" MAINS	APPROVED	REVISED
		March 2008	AUG 2019
		DD-844-01	

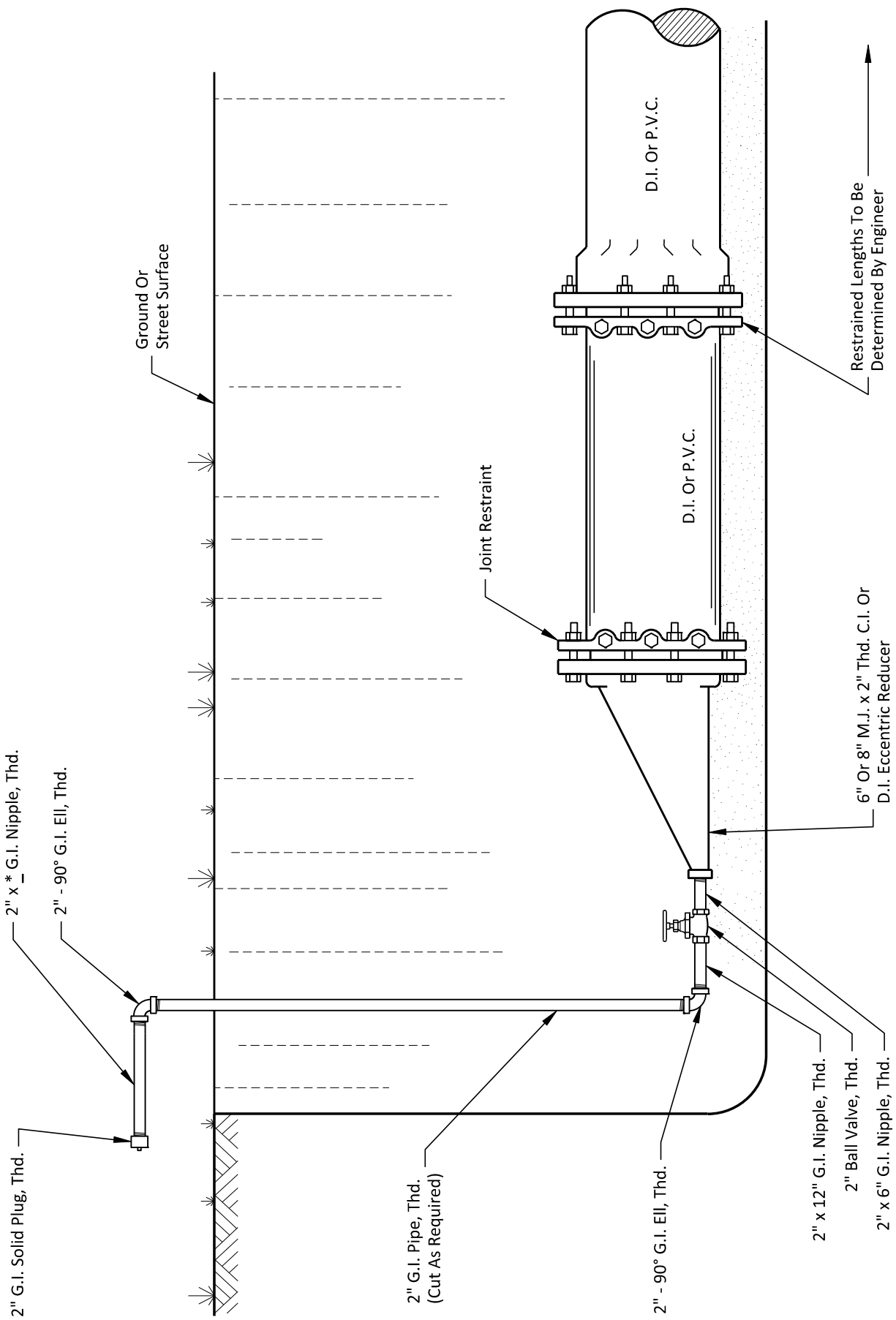

NOTE:
FITTINGS FOR 6" AND 8" PIPE

PROPERTY OF
SAN ANTONIO WATER SYSTEM
SAN ANTONIO, TEXAS

**2" (TEMPORARY)
BLOW-OFF ASSEMBLY
ON 6" & 8" MAINS
(JOINT RESTRAINT)**

APPROVED
MARCH 2008

REVISED
AUG 2019

DD-844-01

SHEET
3 OF 4

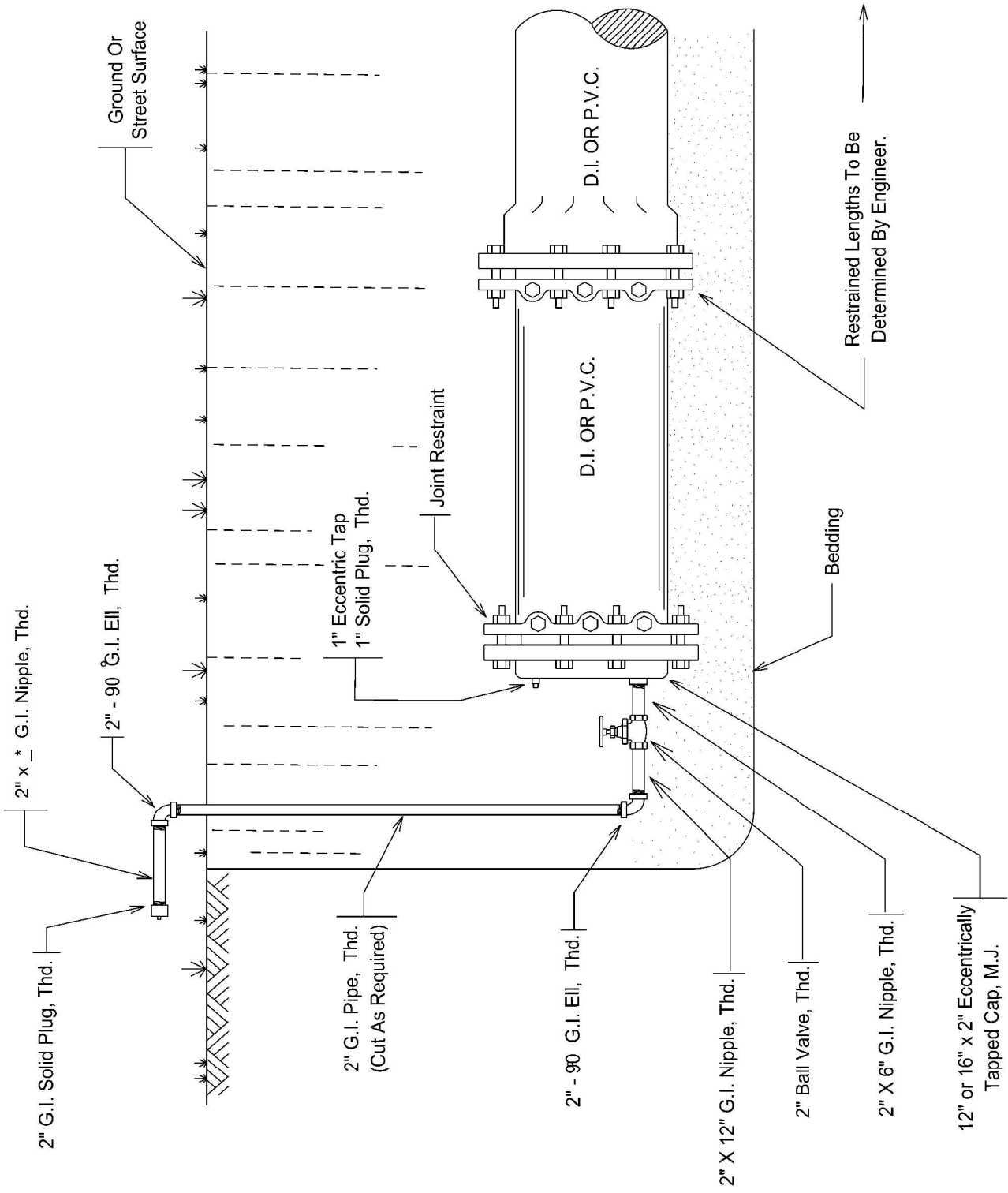

* Cut as required to extend beyond excavation.

NOTE:
FITTINGS FOR 12" AND 16" PIPE

PROPERTY OF SAN ANTONIO WATER SYSTEM SAN ANTONIO, TEXAS	2" (TEMPORARY) BLOW-OFF ASSEMBLY ON 12" & 16" MAINS (JOINT RESTRAINT)	APPROVED	REVISED
		March 2008	AUG 2019
		DD-844-01	

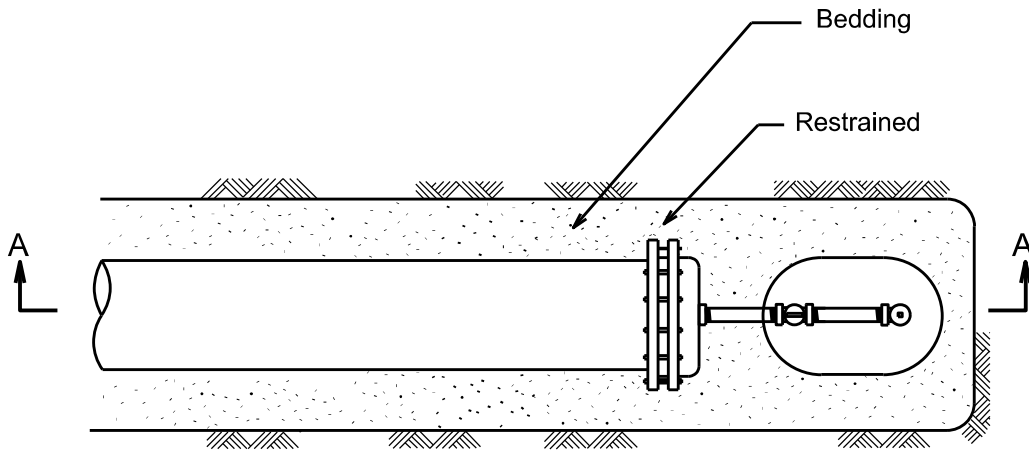

PLAN

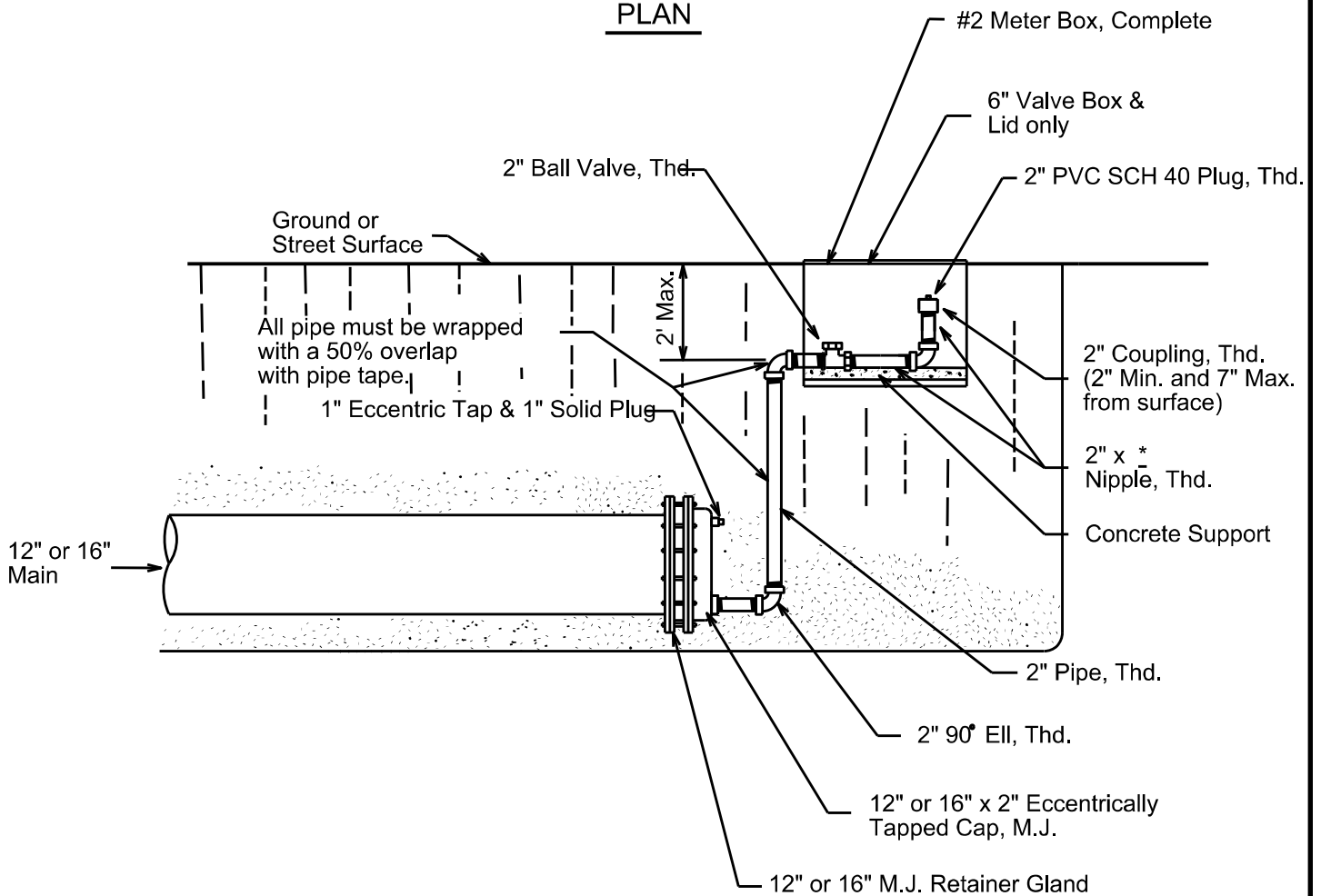

SECTION A-A

* Cut to fit in meter box.

PROPERTY OF SAN ANTONIO WATER SYSTEM SAN ANTONIO, TEXAS	2" PERMANENT BLOW-OFF ASSEMBLY ON 12" & 16" MAINS	APPROVED	REVISED
		MARCH 2008	MAY 2013
		DD-844-02	SHEET <u>1</u> OF <u>5</u>

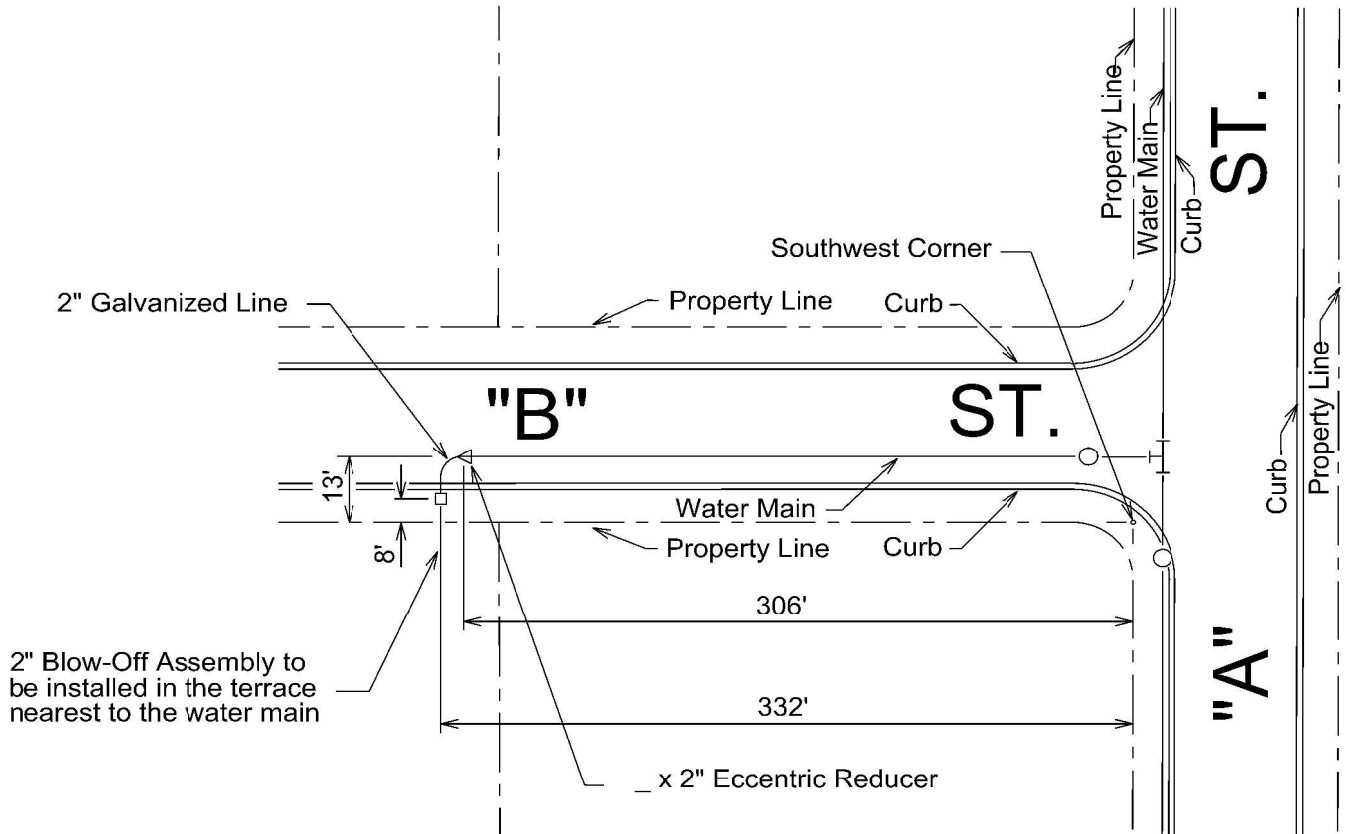

BLOW-OFF MEASUREMENT: From the Southwest Corner of "A" St. and "B" St. West 306' and North 13' to Eccentric Reducer, and West 332' and North 8' to Blow-Off Assembly

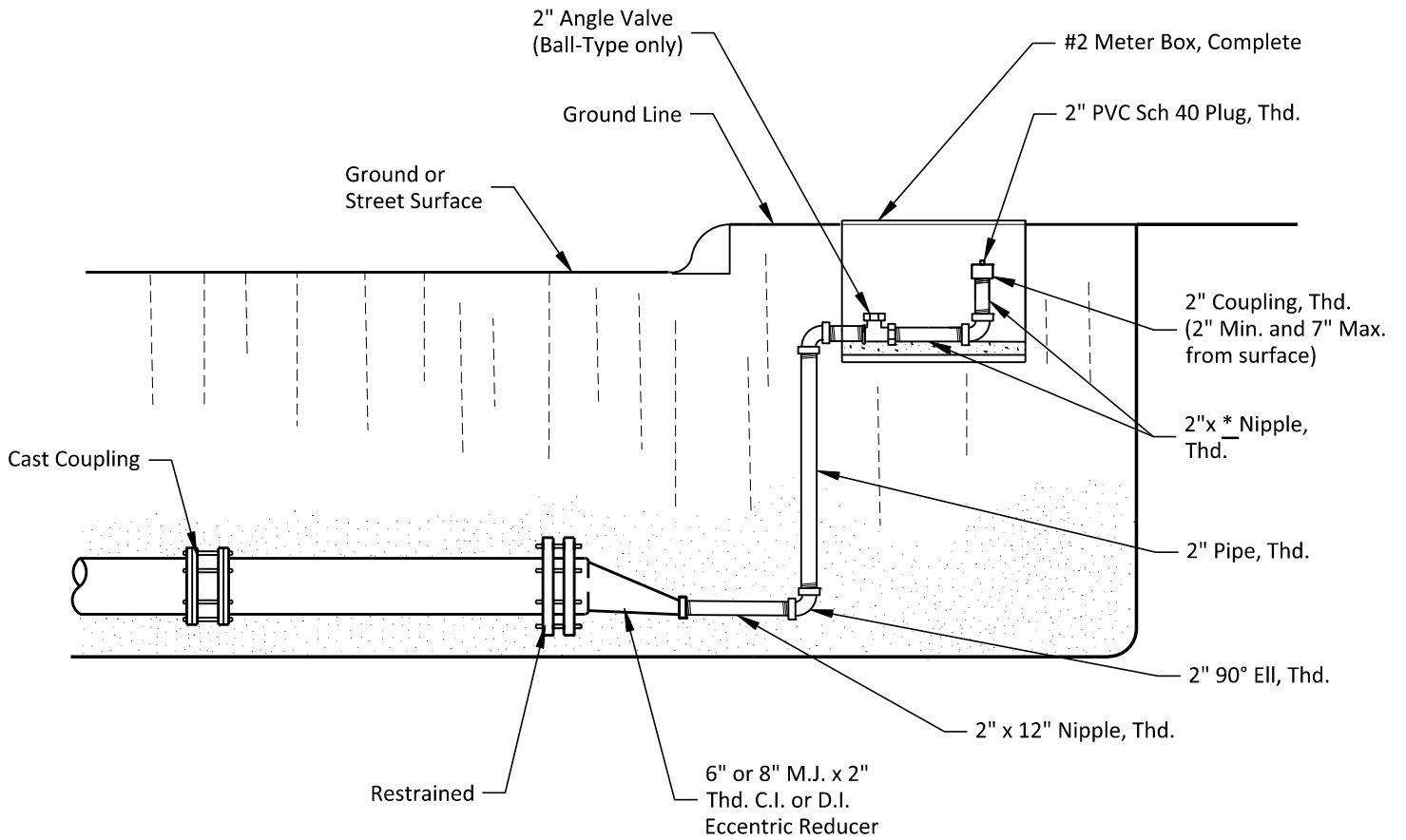

* Cut to fit in meter box

PROPERTY OF SAN ANTONIO WATER SYSTEM SAN ANTONIO, TEXAS	2" PERMANENT BLOW-OFF ASSEMBLY ON 6" & 8" MAINS	APPROVED	REVISED
		MARCH 2008	AUG 2019
		DD-844-02	

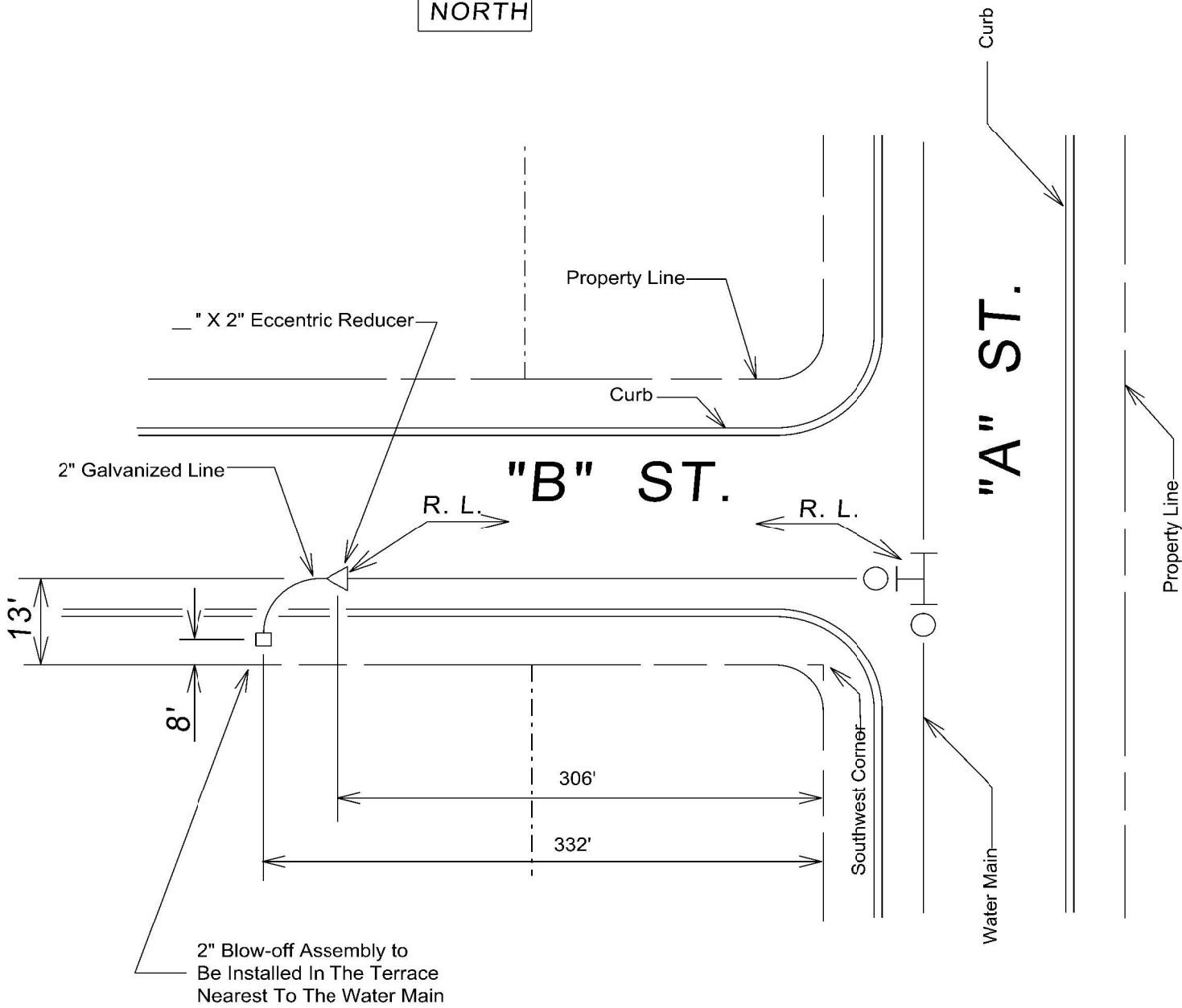

2" BLOW-OFF MEASUREMENT:
 FROM THE SOUTHWEST CORNER OF "A" ST. AND "B" ST.
 WEST 306' AND NORTH 13' TO ECCENTRIC REDUCER, AND
 WEST 332' AND NORTH 8' TO BLOW-OFF ASSEMBLY

R. L. = RESTRAINED LENGTHS TO BE
 DETERMINED BY ENGINEER.

PROPERTY OF SAN ANTONIO WATER SYSTEM SAN ANTONIO, TEXAS	TYPICAL BLOW-OFF ARRANGEMENT ON DEAD END MAINS (JOINT RESTRAINT)	APPROVED	REVISED
		March 2008	AUG 2019
		DD-844-02	

NOTE:
 EMBED ALL EXTERIOR METAL
 SURFACES IN SILICA SAND

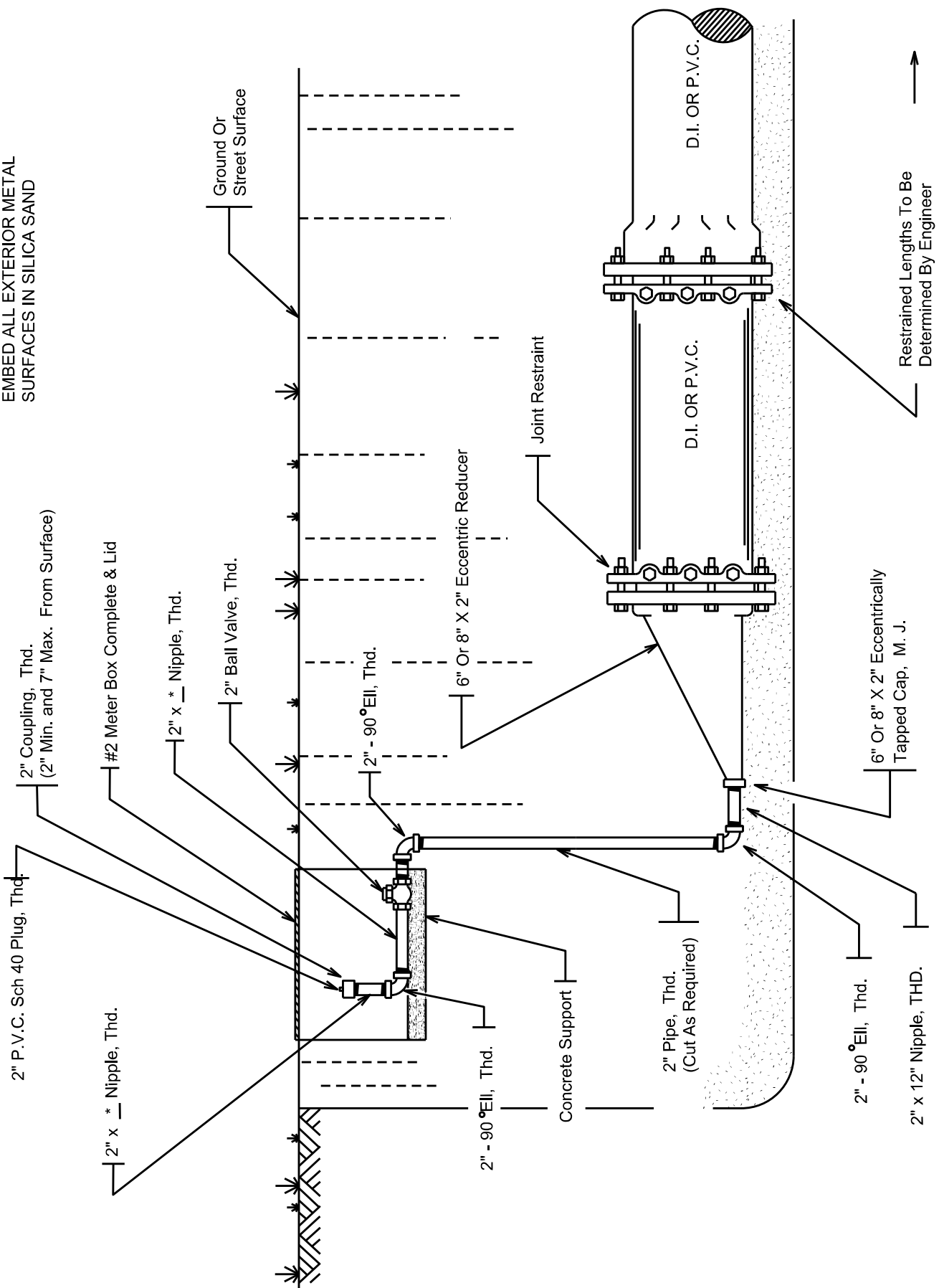

* Cut to fit in meter box.

Restrainted Lengths To Be
 Determined By Engineer

6" Or 8" X 2" Eccentrically
 Tapped Cap, M. J.

2" - 90° Ell, Thd.

2" x 12" Nipple, THD.

2" Pipe, Thd.
 (Cut As Required)

Concrete Support

2" - 90° Ell, Thd.

6" Or 8" X 2" Eccentric Reducer

2" - 90° Ell, Thd.

2" Ball Valve, Thd.

2" x 1/2" Nipple, Thd.

#2 Meter Box Complete & Lid

2" Coupling, Thd.
 (2" Min. and 7" Max. From Surface)

2" P.V.C. Sch 40 Plug, Thd.

2" x 1/2" Nipple, Thd.

Ground Or
 Street Surface

Joint Restraint

D.I. OR P.V.C.

D.I. OR P.V.C.

PROPERTY OF
 SAN ANTONIO WATER SYSTEM
 SAN ANTONIO, TEXAS

2" (PERMANENT)
 BLOW-OFF ASSEMBLY
 ON 6" & 8" D. I./P.V.C. MAINS
 (JOINT RESTRAINT)

APPROVED
 March 2008

REVISED
 MAY 2013

DD-844-02

SHEET
 5 OF 5

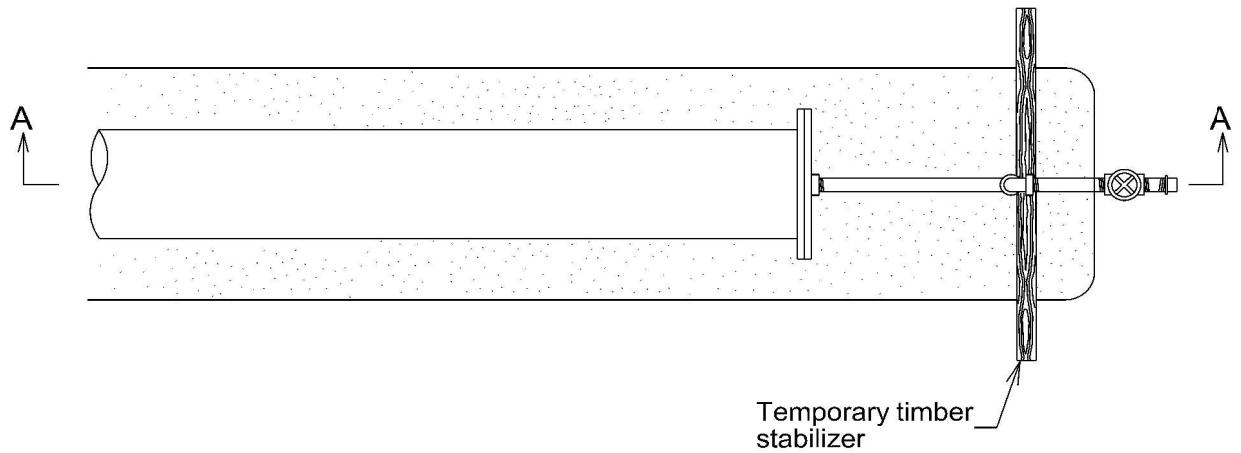

PLAN

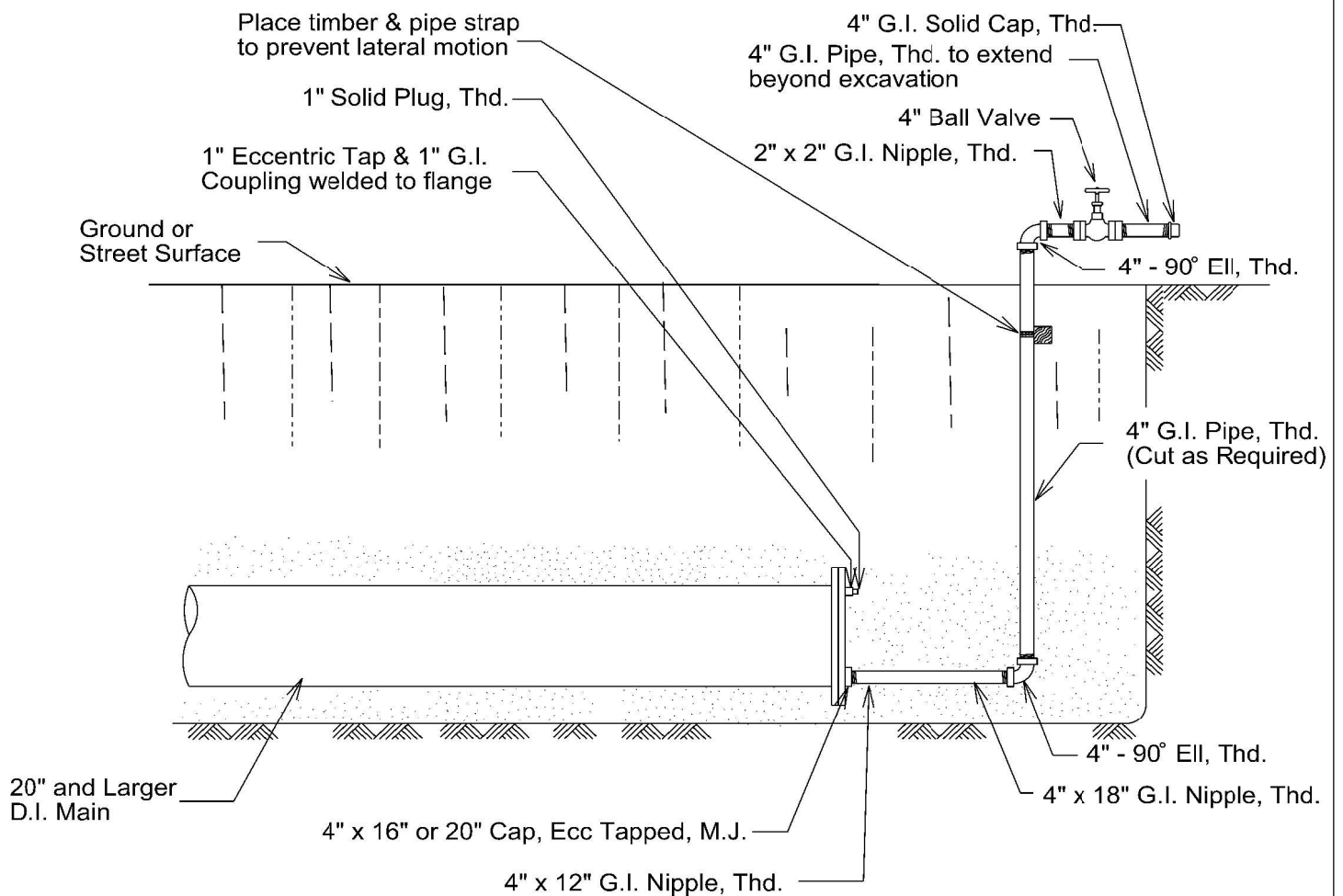

SECTION A-A

PROPERTY OF
SAN ANTONIO WATER SYSTEM
SAN ANTONIO, TEXAS

**4" TEMPORARY
BLOW-OFF ASSEMBLY
20" AND LARGER D.I. MAIN**

APPROVED
March 2008

REVISED
AUG 2019

DD-844-04

SHEET
1 OF 4

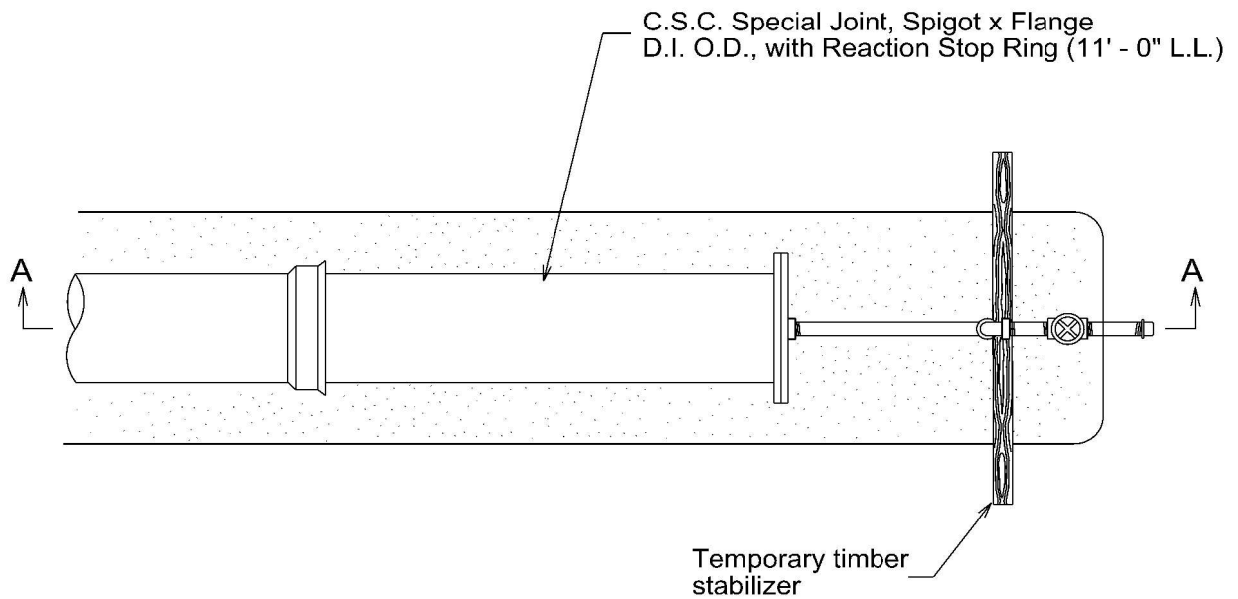

PLAN

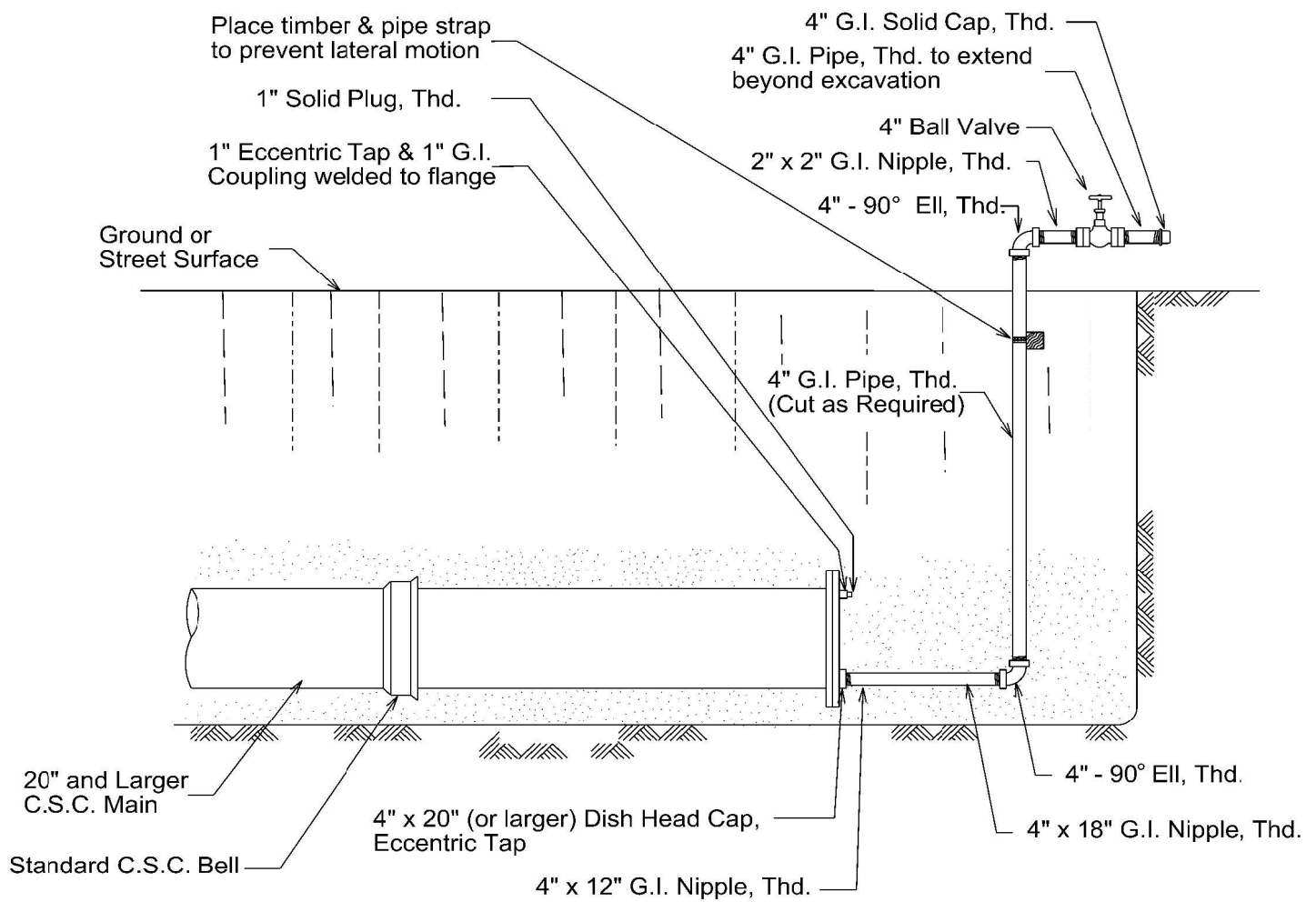

SECTION A-A

* Resilient Seat

PROPERTY OF
SAN ANTONIO WATER SYSTEM
SAN ANTONIO, TEXAS

**4" TEMPORARY
BLOW-OFF ASSEMBLY
20" AND LARGER C.S.C. MAIN**

APPROVED

March 2008

REVISED

AUG 2019

DD-844-04

SHEET
2 OF 4

NOTE:
Embed All Exterior Metal
Surfaces in Silica Sand

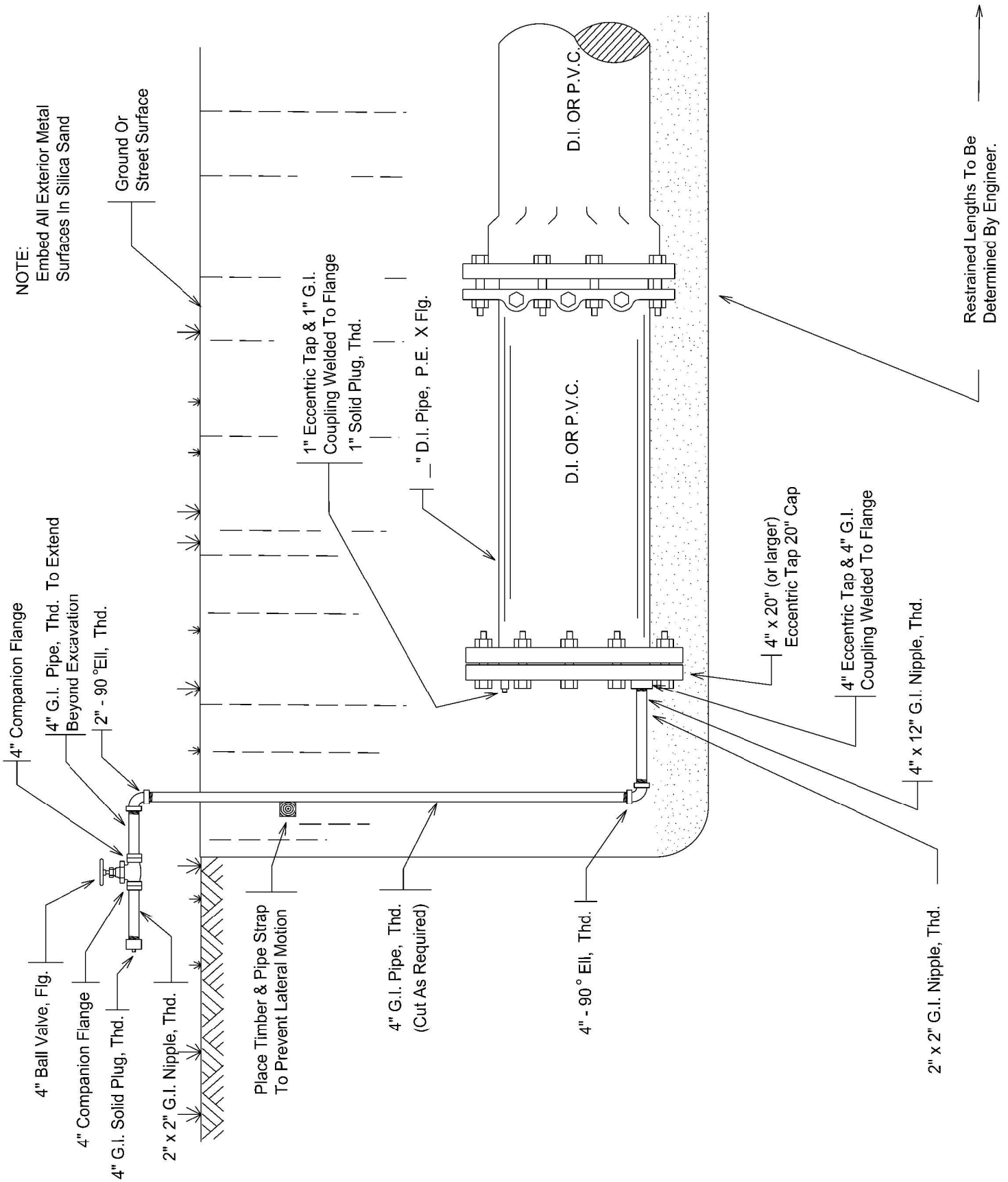

PROPERTY OF
SAN ANTONIO WATER SYSTEM
SAN ANTONIO, TEXAS

4" (TEMPORARY)
BLOW-OFF ASSEMBLY 20"
AND LARGER D. I./P.V.C. MAIN
(JOINT RESTRAINT)

APPROVED
March 2008

REVISED
AUG 2019

DD-844-04

SHEET
3 OF 4

NOTE:
Embed All Exterior Metal Surfaces In Silica Sand

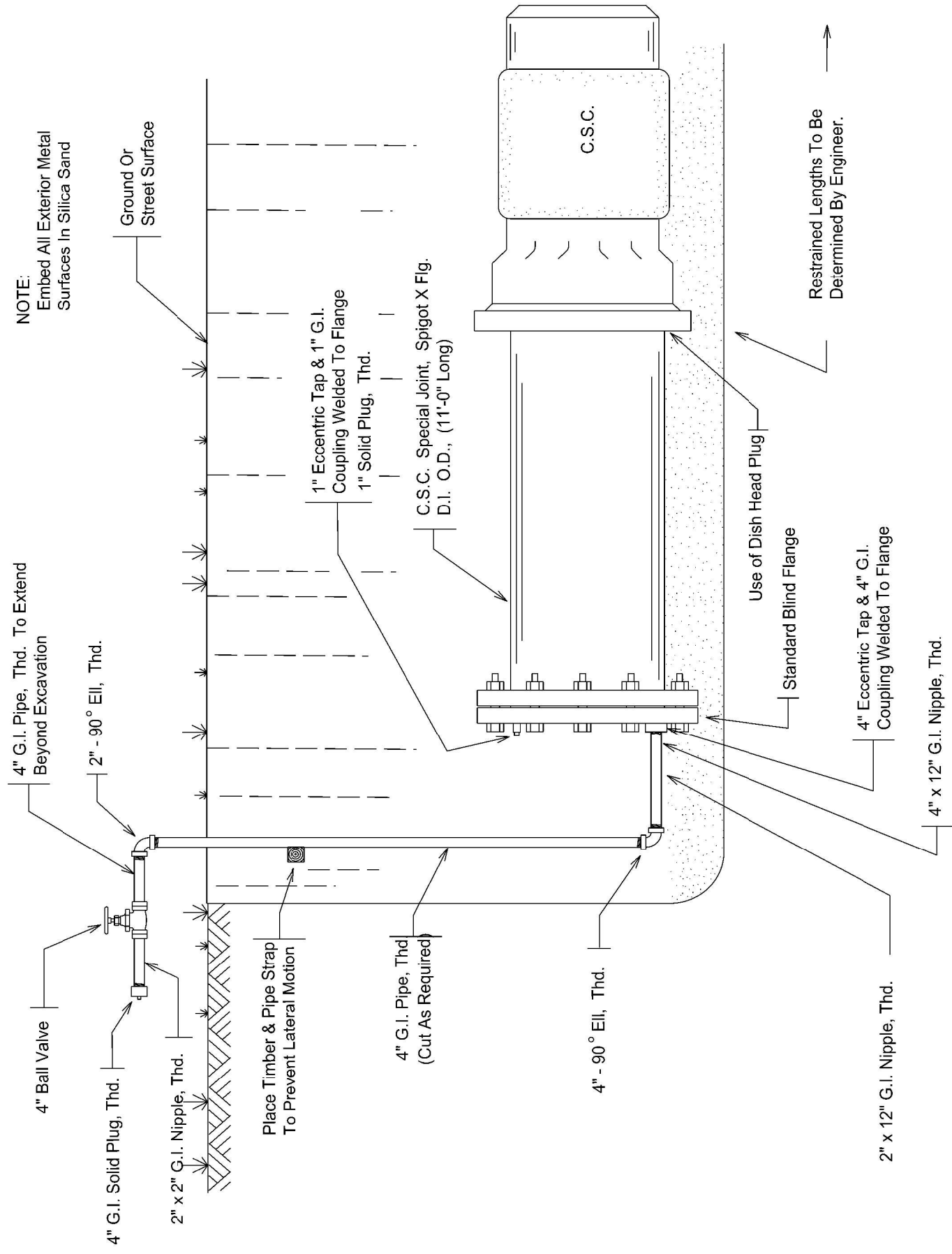

4" G.I. Pipe, Thd. To Extend Beyond Excavation

2" - 90° Ell, Thd.

4" Ball Valve

4" G.I. Solid Plug, Thd.

2" x 2" G.I. Nipple, Thd.

Place Timber & Pipe Strap To Prevent Lateral Motion

4" G.I. Pipe, Thd (Cut As Required)

4" - 90° Ell, Thd.

2" x 12" G.I. Nipple, Thd.

4" Eccentric Tap & 4" G.I. Coupling Welded To Flange

Standard Blind Flange

Use of Dish Head Plug

1" Eccentric Tap & 1" G.I. Coupling Welded To Flange

1" Solid Plug, Thd.

C.S.C. Special Joint, Spigot X Fig. D.I. O.D., (11'-0" Long)

C.S.C.

Restrained Lengths To Be Determined By Engineer.

PROPERTY OF
SAN ANTONIO WATER SYSTEM
SAN ANTONIO, TEXAS

4" (TEMPORARY)
BLOW-OFF ASSEMBLY
20" AND LARGER C.S.C. MAIN
(JOINT RESTRAINT)

APPROVED
March 2008

REVISED
AUG 2019

DD-844-04

SHEET
4 OF 4

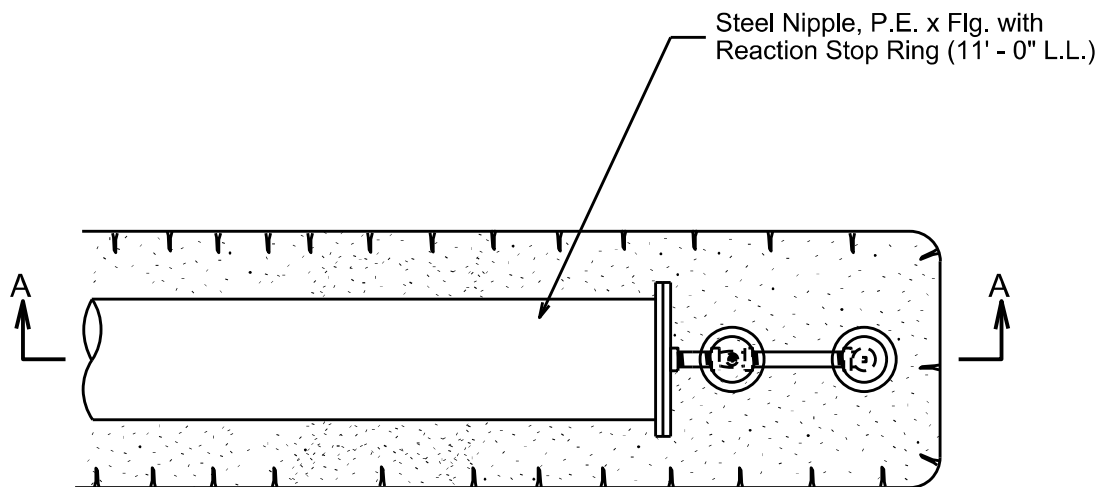

PLAN

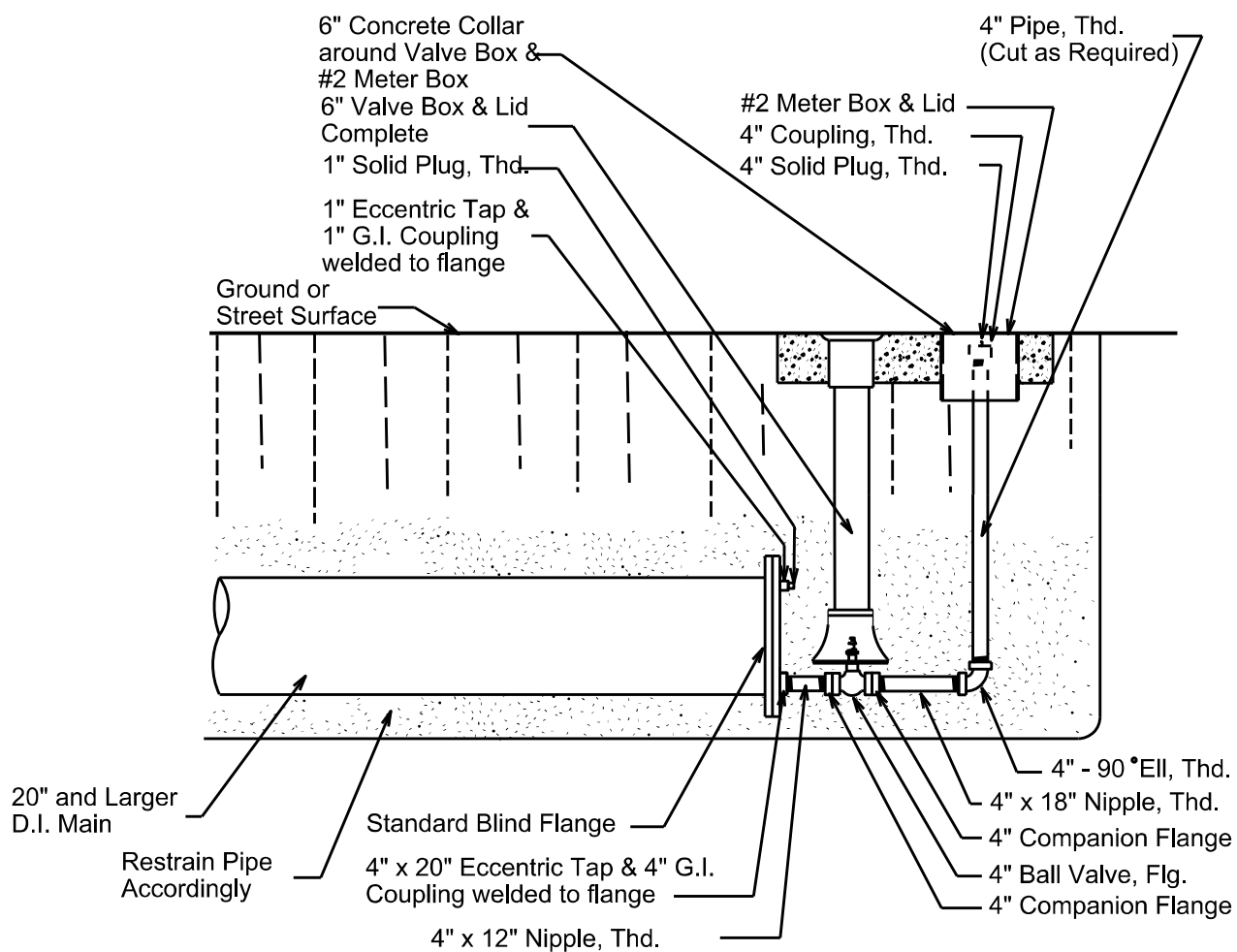

SECTION A-A

PROPERTY OF
SAN ANTONIO WATER SYSTEM
 SAN ANTONIO, TEXAS

**4" PERMANENT
 BLOW-OFF ASSEMBLY
 20" AND LARGER D.I. MAIN**

APPROVED

March 2008

REVISED

MAY 2013

DD-844-05

SHEET

1 OF 4

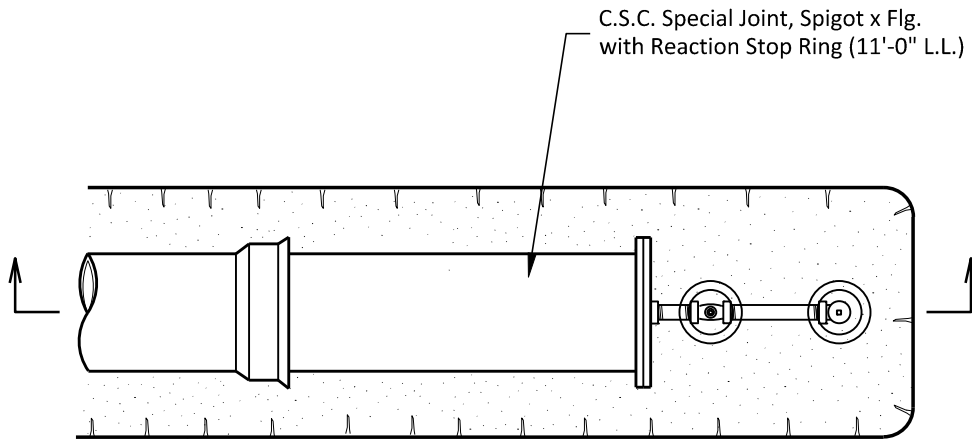

PLAN

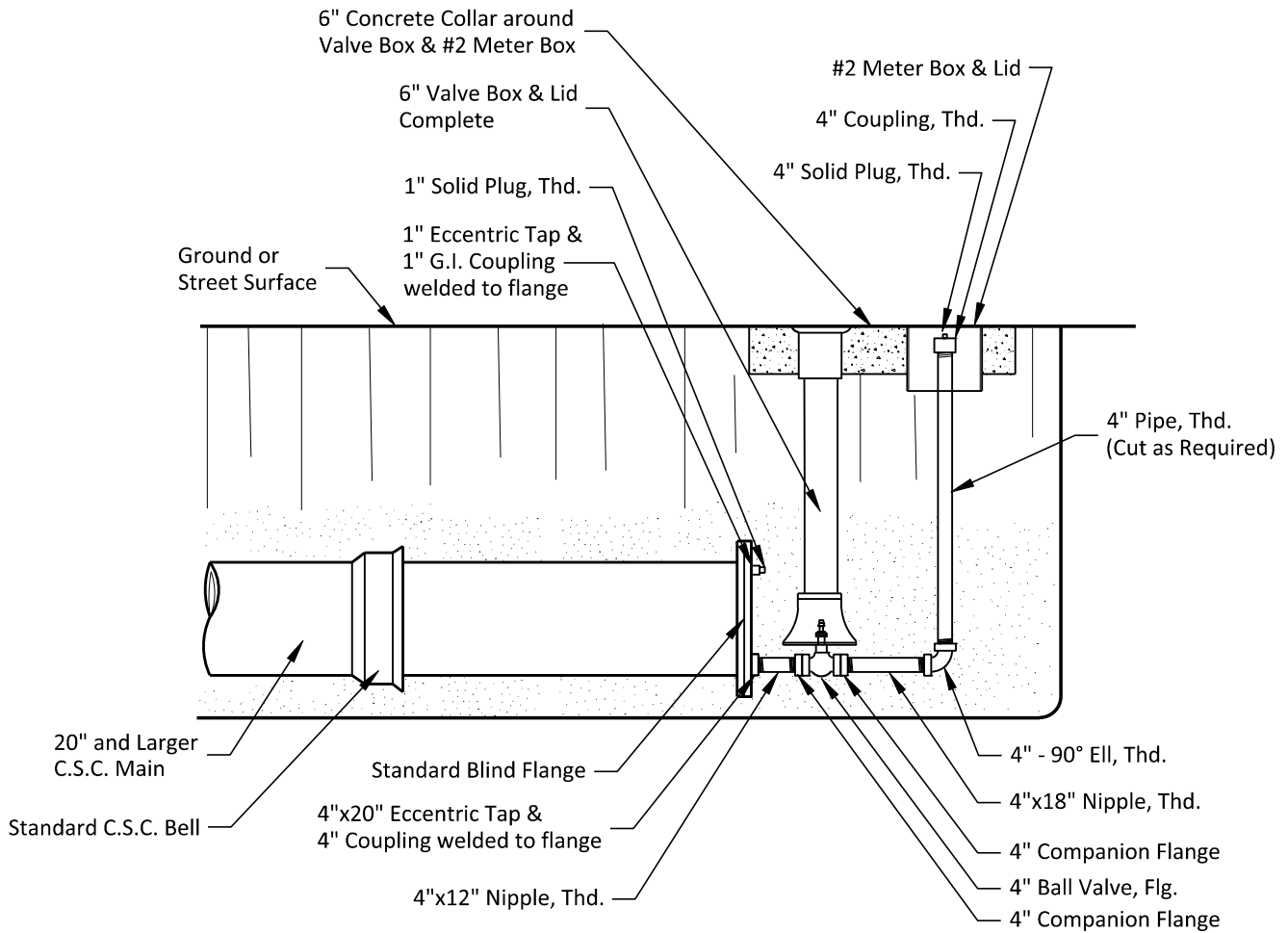

SECTION A-A

PROPERTY OF
SAN ANTONIO WATER SYSTEM
 SAN ANTONIO, TEXAS

4" PERMANENT
 BLOW-OFF ASSEMBLY
 20" AND LARGER C.S.C. MAIN

APPROVED
 MARCH 2008

REVISED
 AUGUST 2019

DD-844-05

SHEET
 2 OF 4

NOTE:
Embed All Exterior Metal
Surfaces in Silica Sand

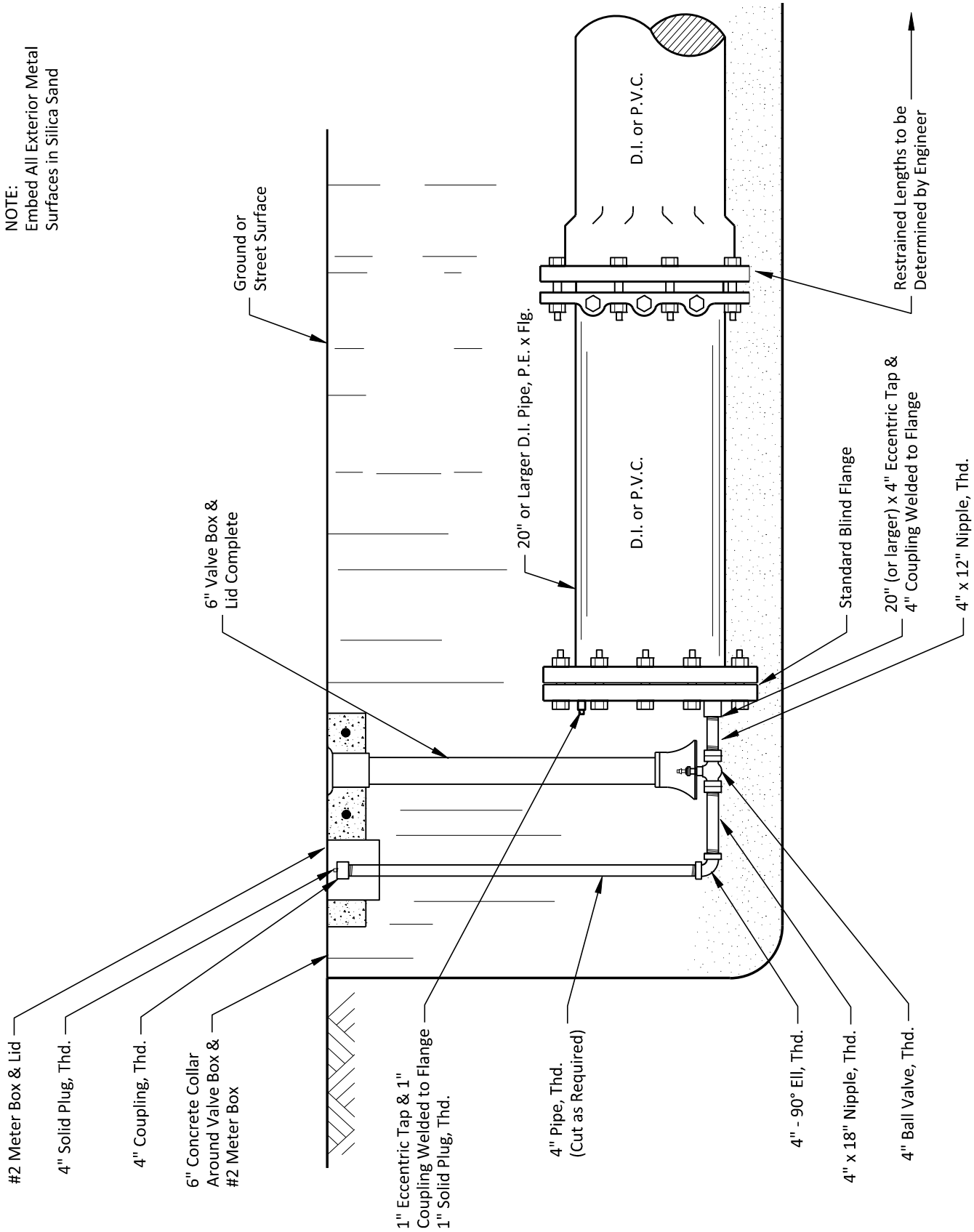

PROPERTY OF SAN ANTONIO WATER SYSTEM SAN ANTONIO, TEXAS	4" (PERMANENT) BLOW-OFF ASSEMBLY ON 20" AND LARGER D.I./P.V.C. MAIN (JOINT RESTRAINT)	APPROVED MARCH 2008	REVISED AUGUST 2019
		DD-844-05	
		SHEET <u>3</u> OF <u>4</u>	

NOTE:
Embed all Exterior Metal
Surfaces in Silica Sand

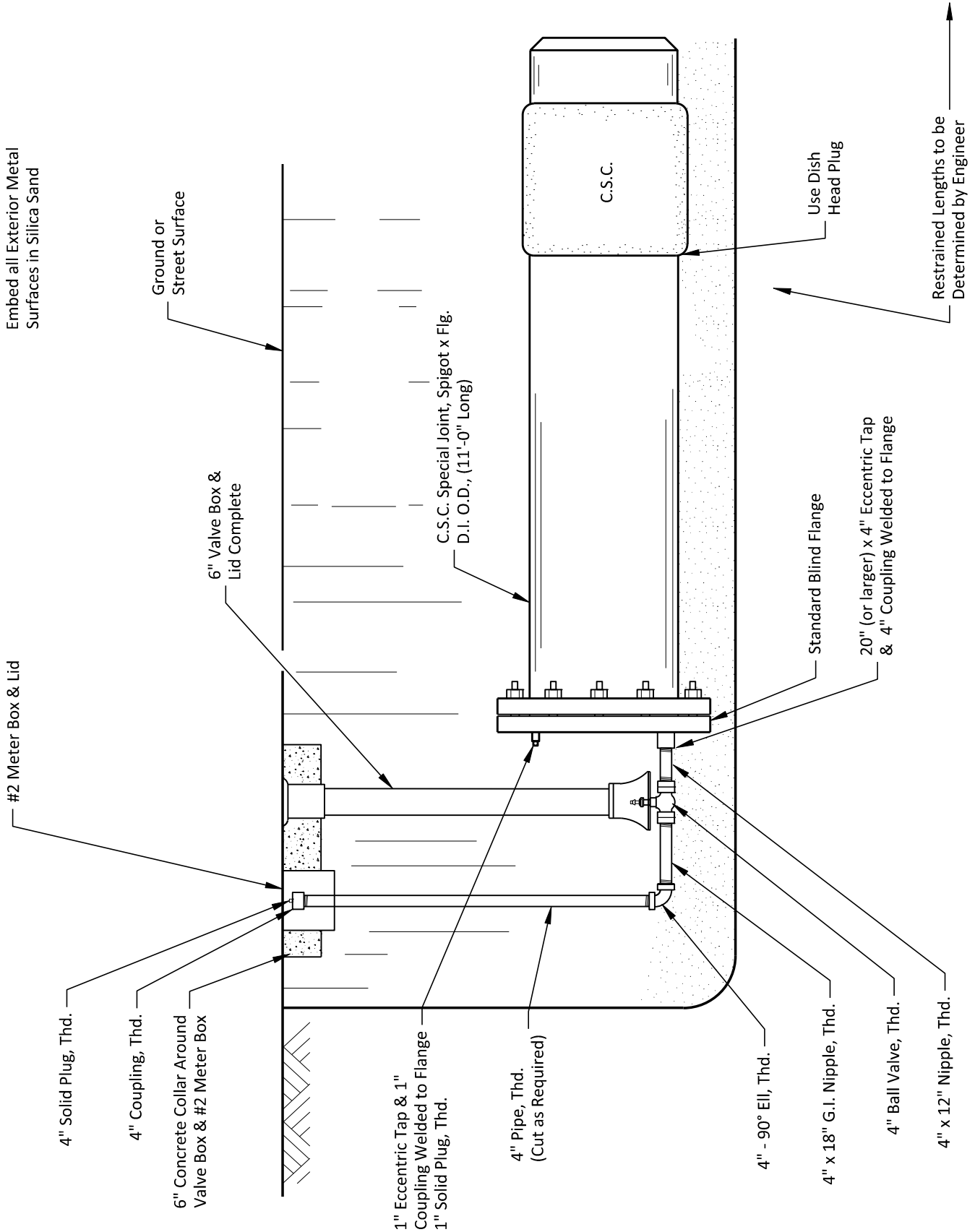

PROPERTY OF
SAN ANTONIO WATER SYSTEM
SAN ANTONIO, TEXAS

**4" (PERMANENT)
BLOW-OFF ASSEMBLY ON 20"
AND LARGER C.S.C. MAIN
(JOINT RESTRAINT)**

APPROVED
MARCH 2008

REVISED
AUGUST 2019

DD-844-05

SHEET
4 OF 4

San Antonio Water System Standard Specifications for Construction

ITEM NO. 846

Air Release Assemblies

846.1 DESCRIPTION: This item shall consist of air release assemblies installed in accordance with these specifications and as directed by the Engineer.

846.2 REFERENCED STANDARDS: Reference standards cited in this Specification Item No. 846 refer to the current reference standard published at the time of the latest revision date.

1. San Antonio Water System (SAWS):
 - a. Specifications for Water and Sanitary Sewer Construction
 - b. SAWS Materials Specifications
2. City Of San Antonio (COSA):
 - a. Standard Specifications for Construction
3. American Society for Testing and Materials International (ASTM)
 - a. ASTM A 48 - Standard Specification for Gray Iron Castings.
 - b. ASTM A 126 - Standard Specification for Gray Iron Castings for Valves, Flanges, and Pipe Fittings.
 - c. ASTM A 240 - Standard Specification for Heat-Resisting Chromium and Chromium-Nickel Stainless Steel Plate, Sheet and Strip for Pressure Vessels.
 - d. ASTM A 276 - Standard Specification for Stainless Steel Bars and Shapes.
 - e. ASTM A 313 - Standard Specification for Stainless Steel Spring Wire.
 - f. ASTM B 584 - Standard Specification for Copper Alloy Sand Castings for General Applications.

846.3 SUBMITTALS: Contractor shall submit manufacturer's product data, instructions, recommendations, shop drawings, and certifications. All submittals shall be in accordance with Engineer's requirements and submittals shall be approved prior to delivery.

846.4 MATERIALS: The materials for air release assemblies installation and adjustment shall conform to the specifications contained within the latest revision of SAWS' Material Specification 29-01, "Air Release, Vacuum and Combination Air Valves."

846.5 CONSTRUCTION: Air release assemblies shall be installed at the location shown in the contract documents or as directed by the Engineer.

1. Air release assemblies in an open trench water main installation shall be installed in accordance with DD 846 Drawing Series and shall include the valve, valve boxes, pipe, fittings, accessories and appurtenances.
2. It shall include the service line and tap to the main line.
3. Air release assemblies installed in parkways or easements and adjacent to street pavements shall be installed in accordance with DD 846 Drawing Series regardless of size.

San Antonio Water System Standard Specifications for Construction

4. Air release, vacuum, and combination air valves shall incorporate an air collection trap in the form of an enlarged pipeline riser installed on the main pipe leading to the air valve connection as depicted in Standard Drawing DD-846 Series.
5. Air release assemblies installed on steel pipe attached to a bridge structure shall include the outlet on the steel pipe, valve, valve box, pipe, fittings, security enclosure, accessories, and appurtenances.

846.6 MEASUREMENT: Air release and combination air release valve assemblies will be measured by the unit of each such assembly of the various sizes of air release assemblies installed.

846.7 PAYMENT: Payment for air release valve and combination air release valve assemblies will be made at the unit price bid for each such assembly of the various sizes installed in accordance with the details shown in the DD 846 Drawing Series.

1. Payment shall also include: excavation, selected embedment material, backfill, compaction, compaction testing, anti-corrosion embedment when specified, freeze protection for mains on bridges, blocking, and various types and sizes of meter boxes, fittings, valve marker, valve, valve boxes, pipe, accessories and appurtenances, service line and tap to the main line, security enclosure adapters, couplings, anchors, hauling and disposition of surplus excavated material, including all existing pipe, fittings, appurtenances to be abandoned or removed, surface and pavement restoration, installation of all-weather surface, and other required testing.
2. Materials paid on site will be in accordance with Table 1 of Specification Item No. 100 Mobilization.

-End of Specification-

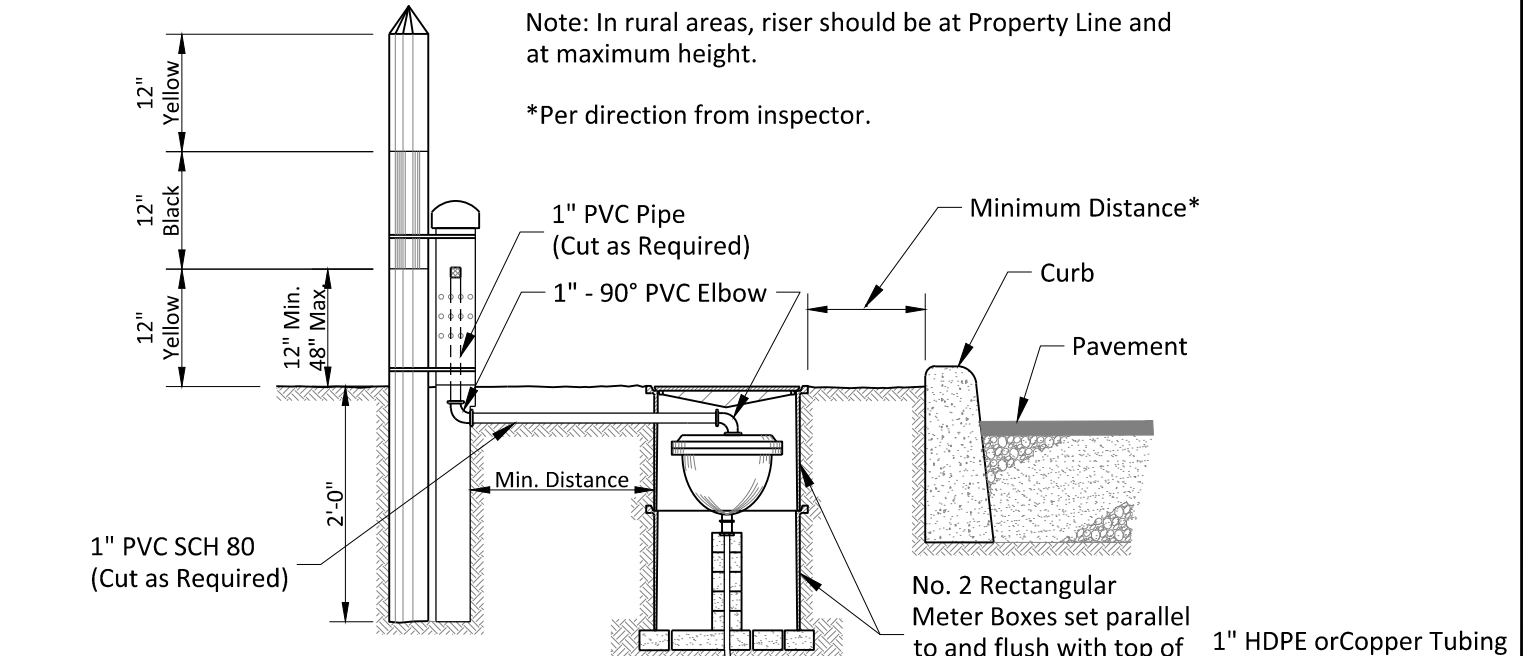
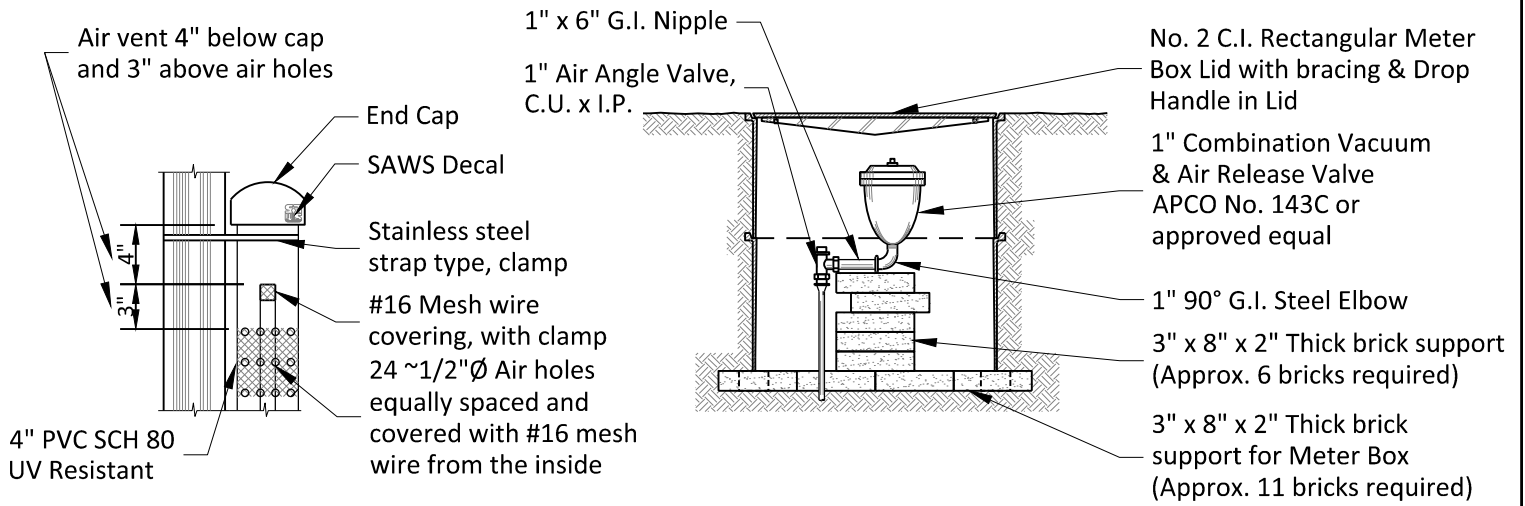

Note: In rural areas, riser should be at Property Line and at maximum height.

*Per direction from inspector.

TABLE 1 - Enlarged Pipe Riser for Potable, Reclaimed, and Wastewater mains 6" and Larger

D, Nominal Diameter of Main, In.	Minimum d, in.	Minimum h, in.	Comments
6	6.0	6.0	6 MJ x 6 MJ x 6 FLG DI Tee
8	8.0	8.0	12 MJ x 12 MJ x 12 FLG DI Tee
12	12.0	12.0	16 MJ x 16 MJ x 12 FLG DI Tee
16	12.0	9.6	24 MJ x 24 MJ x 18 FLG DI Tee
24	18.0	14.4	30 MJ x 30 MJ x 18 FLG DI Tee
30	18.0	18.0	36 MJ x 36 MJ x 24 FLG DI Tee
36	24.0	21.6	42 MJ x 42 MJ x 24 FLG DI Tee
42	24.0	25.2	48 MJ x 48 MJ x 24 FLG DI Tee
48	24.0	28.8	Welded-on FLG Outlet
54	30.0	32.4	Welded-on FLG Outlet
60	36.0	36.0	Welded-on FLG Outlet
66	24.0	23.1	Welded-on FLG Outlet
72	24.0	25.2	Welded-on FLG Outlet

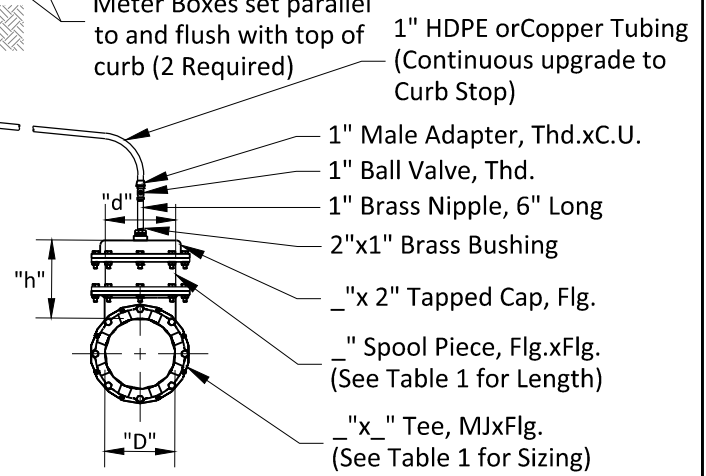

Air Collection Traps in Air Valve Piping Notes:

1. Dimensions derived from AWWA Manual 2nd Edition: Chapter 6 M51 Air Valves:

Air-Release, Air/Vacuum & Combination

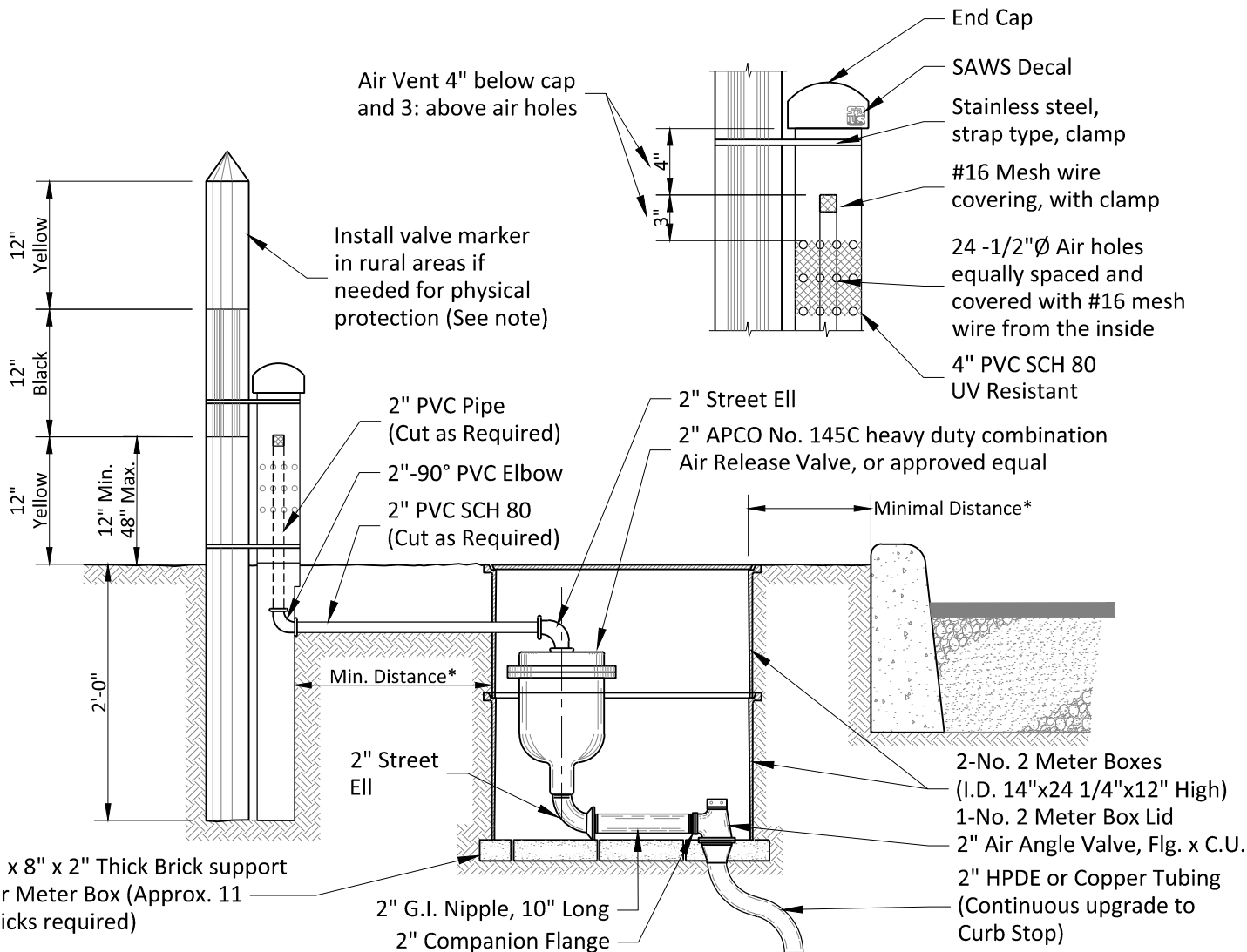

Note: In rural areas, riser should be at Property Line and at maximum height.

*Per direction from inspector.

TABLE 1 - Enlarged Pipe Riser for Potable, Reclaimed, and Wastewater mains 6" and Larger

D, Nominal Diameter of Main, In.	Minimum d, in.	Minimum h, in.	Comments
6	6.0	6.0	6 MJ x 6 MJ x 6 FLG DI Tee
8	8.0	8.0	12 MJ x 12 MJ x 12 FLG DI Tee
12	12.0	12.0	16 MJ x 16 MJ x 12 FLG DI Tee
16	12.0	9.6	24 MJ x 24 MJ x 18 FLG DI Tee
24	18.0	14.4	30 MJ x 30 MJ x 18 FLG DI Tee
30	18.0	18.0	36 MJ x 36 MJ x 24 FLG DI Tee
36	24.0	21.6	42 MJ x 42 MJ x 24 FLG DI Tee
42	24.0	25.2	48 MJ x 48 MJ x 24 FLG DI Tee
48	24.0	28.8	Welded-on FLG Outlet
54	30.0	32.4	Welded-on FLG Outlet
60	36.0	36.0	Welded-on FLG Outlet
66	24.0	23.1	Welded-on FLG Outlet
72	24.0	25.2	Welded-on FLG Outlet

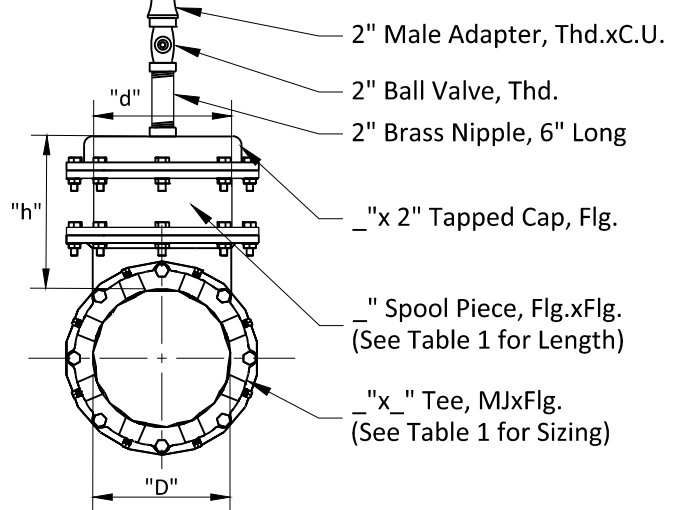

Air Collection Traps in Air Valve Piping Notes:

1. Dimensions derived from AWWA Manual 2nd Edition: Chapter 6 M51 Air Valves: Air-Release, Air/Vacuum & Combination

10-10

SPECIFICATIONS FOR GRAY-IRON AND DUCTILE

IRON FITTINGS

REVISED DECEMBER 2011

1. **SCOPE**

This specification covers ductile-iron fittings 3 inches through 48 inches in size designed and manufactured for use with gray-iron, ductile-iron, PVC C-900 or PVC C905 pipe. Standard, compact and anchor fittings included herein are of the following types of joints:

Flanged
Mechanical Joint

2. **GENERAL REQUIREMENTS**

- a) Except as otherwise modified or supplemented herein, the latest revision of AWWA Standard C110 for Gray-Iron and Ductile-Iron Fittings, 3 inch through 48 inch for Water and other Liquids and AWWA Standard C153 for Ductile-Iron Compact Fittings, shall govern the design, manufacture, and testing of all fittings under this specification.
- b) For 3 through 24-inch size range, the pressure rating of all fittings shall be a minimum of 250 psi. The working pressure for all fittings of size greater than 24 inches shall be a minimum of 150 psi unless a change in pressure rating is directed by purchase documents.
- c) Fittings shall be furnished with the types of end combination specified.
- d) Anchor fittings shall be furnished in size and type or length as specified.
- e) Flanged fittings shall be faced and drilled in accordance with ANSI Specification B16.1, Class 125.
- f) The exterior of all fittings shall be provided with a petroleum asphaltic coating in accordance with the latest revision of AWWA Standard C110. The interior of flanged fittings supplied under this specification shall be either cement-mortar lined in accordance with the latest revision of AWWA Standard C104 or lined with a petroleum asphaltic material in accordance with the latest revision of AWWA Standard as specified. The interior of all other fittings supplied under this specification shall be cement-mortar lined in accordance with the latest revision of AWWA Standard C104.
- g) Fittings for 2-inch size shall be manufacturers' standard design designed in accordance with applicable design standards of AWWA C110.

**SAN ANTONIO WATER SYSTEM
SPECIFICATIONS FOR
RESILIENT-SEATED GATE AND TAPPING VALVES
FOR WATER SUPPLY SERVICE
ANSI/AWWA C509-01
3 IN., 4 IN., 6 IN., 8 IN., 10 IN., 12 IN., 16 IN., & 20 IN.
Revised February 2013**

1. **SCOPE**

This product specification covers resilient seated gate valves, with nominal diameters of 3 in., 4 in., 6 in., 8 in., 10 in., 12 in., 16 in., and 20 in. Sizes refer to the nominal diameter, in inches, of the waterway through the inlet and outlet connections and the closure area. All products furnished shall conform to the American National Standards Institute and American Water Works Association C509 Standard (ANSI/AWWA C509- 01) or latest revision thereof.

2. **DEFINITIONS**

All definitions are defined according to ANSI/AWWA C509-01.

- a. **Cosmetic Defect:** A blemish, which has no effect on the ability of the component to meet the structural design and production test requirements of this standard. Should the blemish or the activity of plugging, welding, grinding, or repairing of such blemish cause the component to fail these requirements, then the blemish shall be considered a structural defect.
- b. **Flanged Joint:** The flanged and bolted joint as described in ANSI/AWWA C110/A21.10.
- c. **Mechanical Joint:** The gasket and bolted joint as described in ANSI/AWWA C111/A21.11.
- d. **Push-on Joint:** The single rubber gasket joint as described in ANSI/AWWA C111/A21.11.
- e. **Structural Defect:** A flaw that causes the component to fail the structural design or test requirement of this standard. This includes, but is not limited to imperfections that result in leakage through the walls of a casting, failure to meet the minimum wall-thickness requirement, or failure to meet production tests.

RESILIENT-SEATED GATE AND TAPPING VALVES
SPECIFICATION NUMBER 21-02

- f. Tapping Valve: A special gate valve designed with end connections and an unobstructed waterway to provide proper alignment and positioning of a tapping sleeve, valve, and machine for tapping pipe dry or under pressure as described in AWWA C509 Section 1.2 Definitions and MSS SP-60.

3. **GENERAL REQUIREMENTS**

- a. Except as otherwise modified or supplemented herein, AWWA Standard C509-01 or the latest revision thereof, shall govern the design, component materials, construction; manufacture and testing of all resilient seated gate valves. Valves shall be suitable for frequent operation as well as service involving long periods of inactivity. Valves shall be NSF-61 certified.
- b. The San Antonio Water System reserves the right to limit the purchase of resilient seat gate valves from manufacturers and to the models specified, as shown on ATTACHMENT I, provided such resilient seat gate valves conform to the provision contained herein.
- c. The minimum design working water pressure for gate valves with nominal diameters of 3 in., 4 in., 6 in., 8 in., 10 in., and 12 in. shall be 200 psig unless otherwise specified.
- d. The minimum design working water pressure for gate valves with nominal diameters of 16 in., and 20 in. shall be 150 psig unless otherwise specified.
- e. Valves shall be resilient-seated types, bronze mounted with non-rising stems. The closure member shall be fully encapsulated by an elastomer without thin spots or voids. When open the valve shall have a clear, full-port, unobstructed waterway.
- f. Gray iron, ductile iron, steel, brass and bronze materials shall meet or exceed the material requirements of Section 2: Materials of AWWA C509-01.
- g. Gaskets, O-rings, Coatings, and elastomers shall meet or exceed the material requirements of Section 2: Materials of AWWA C509-01.

RESILIENT-SEATED GATE AND TAPPING VALVES
SPECIFICATION NUMBER 21-02

- h. The gate valves shall be designed and constructed for installation in either a horizontal or vertical position. Valves shall be designed for buried installation with stem in the vertical position and shall be furnished for mounting in a horizontal pipeline, unless otherwise specified.
- i. Valve components of brass or bronze shall be manufactured to ASTM recognized alloy specifications of low zinc content bronze, as shown in Table 1 of Section 2.2.4. of ANSI/AWWA Standard C509-01 or the latest revision thereof. Materials for the stem have minimum yield strength of 40,000 psi. A minimum elongation in 2 inches of 12% and shall be made of bronze per ASTM B763, alloy number UNS C99500. A maximum zinc content of 2% as shown in Table 2 Chemical Requirements of ASTM B763-96 or the latest revision thereof. Stem nut material shall be ASTM B62 UNS C83600 or ASTM B584 UNS C84400. The stem shall have a visible external marking at the top to indicate low-zinc, high strength material. The marking shall include a red plastic or neoprene washer placed around the top of the stem under the operating nut.
- j. Valve ends shall be either flanged, tapping valve, mechanical joint, push-on joint or any combination thereof, as specified. All mechanical joint valves shall be supplied with glands, bolts, and gaskets. Valve body bolts and nuts shall meet the strength requirements of ASTM A307 with dimensions conforming to ANSI B18.2.1. The size of the bolt head shall be equal to the size of the nut and shall be stainless steel in accordance with ASTM 276.
- k. All gate valves shall open right (clockwise), unless otherwise specified.
- l. The following parts of the valve shall be made of either gray or ductile iron: bonnet, body, yoke, wrench nut, O-ring packing plate or seal plate, and gland follower. The gate may be made of gray or ductile iron.
- m. If glands and bushings are used for NRS valves they shall be made of ASTM B763 bronze UNS C99500. The stem shall be made of cast, forged, or rolled ASTM B763 bronze UNS C99500. The stem nut material shall be ASTM B62 bronze UNS C83600 or ASTM B584 bronze UNS C84400. The gate may be made of bronze ASTM B763 bronze UNS C99500. Stem seals shall be “O” ring type. The seals shall be designed for dynamic applications.

RESILIENT-SEATED GATE AND TAPPING VALVES
SPECIFICATION NUMBER 21-02

The design shall be such that the seal above the stem collar can be replaced with the valve under full pressure in the fully open position. Materials for the “O” ring packing plate shall be in accordance with Section 4.8.3 of the ANSI/AWWA C509-01 Standard or the latest revision thereof.

- n. Enclosed and buried valves shall be coated inside and outside with a fusion bonded epoxy having a nominal 8 mils dry film thickness, which meets or exceeds AWWA C550-01 and to the maximum extent possible shall be free of holidays. All coatings in contact with the potable water shall be approved for potable water immersion service per ANSI/NSF Standard 61.
- o. The bidder shall submit with his proposal three sets of certified drawings showing the principal dimensions, general construction and material specification of the valve proposed. The number of turns to open (close) shall be clearly noted in the valve information submitted with the proposal documents. The number of turns to open or close the valve shall be consistent for each valve size for each approved manufacturer.
- p. Valves furnished under this specification shall be supplied from the San Antonio Water System approved manufacturer list. To be included on the qualified product list, the manufacturer shall provide an Affidavit of Compliance in accordance with the Section 1.5 of the ANSI/AWWA C509-01 Standard or latest revision thereof, to include compliance with San Antonio Water System Specification No. 21-02. Records of all tests performed in accordance with Section 6.1 and Section 6.2 of the ANSI/AWWA C509-01 Standard or latest revision thereof will be made available or provided. These records will be representative test results for Section 6.1 and certificate of testing for Section 6.2. An affidavit of testing for the valve assembly as outlined in Section 6.2.2 of the ANSI/AWWA C509-01 Standard, (350 ft-lbs) will also be provided. A copy of the manufacturer’s Quality Assurance Program will be submitted. Blueprints and parts list for the valve shall also be provided.

RESILIENT-SEATED GATE AND TAPPING VALVES
SPECIFICATION NUMBER 21-02

- q. All gate valve parts shall be designed to withstand the following two pressure requirements, without being structurally damaged. (1) An internal test pressure of twice the rated design working pressure of the valve. (2) The full rated internal working pressure when the closure member is cycled once from a fully open to a fully closed position against the full rated unbalanced working water pressure. In addition to these pressure requirements, the valve assembly and mechanism shall be capable of withstanding an input torque as follows: 200 ft.-lbs. for a 3-in. nominal diameter. 200 ft.-lbs. for a 4-in. nominal diameter. 300 ft.-lbs. for a 6-in. nominal diameter. 300 ft.-lbs. for a 8-in. nominal diameter. 300 ft.-lbs. for a 10- in. nominal diameter. And 300 ft.-lbs. for a 12-in. nominal diameter. For sizes larger than a 12 in. nominal diameter refer to the manufacturer's specifications.
- r. Resilient seats shall be applied to the gate and shall seat against a corrosion resistant surface. The non-metallic seating surface shall be applied in a manner to withstand the action of line fluids and the operation of the sealing gate under long-term service. A metallic surface shall have a corrosion resistance equivalent to or better than bronze. A non-metallic surface shall be in compliance with ANSI/AWWA C550. The gate must be fully encapsulated by an elastomer without thin spots or voids. Resilient seats shall be bonded. ASTM D429 either method A or method B shall prove the method used for bonding or vulcanizing. For method A, the minimum strength shall not be less than 250 psi. For method B, the peel strength shall be 75 lb./in.
- s. Flanged Ends: The end flanges of flanged valves shall conform to dimensions and drillings of ANSI/AWWA C110/A21.10 or ANSI B16.1, Class 125.
- t. Mechanical Joint Ends: Mechanical joint bell dimensions shall conform to ANSI/AWWA C111/A21.11.
- u. Push-on Joints: Push-on joints shall conform to the requirements of ANSI/AWWA C111/A21.11.
- v. The tapping valves shall be mechanical joints with tapping flange on the other end. The tapping valves shall be furnished complete with glands, bolts, and gaskets. The tapping valve shall have a clear unobstructed waterway.

RESILIENT-SEATED GATE AND TAPPING VALVES
SPECIFICATION NUMBER 21-02

The seat rings shall be of a large diameter to the permit entry of the full diameter tapping machine cutters. The valve end which mates with the tapping sleeve shall have an alignment lip to fit the recess in the tapping sleeve flange for proper alignment. The lip will be dimensioned in accordance with MSS SP-60 for valves 20-inch nominal pipe size and smaller.

- w. All interchangeable parts shall conform to their required dimensions and shall be free from defects that could prevent proper functioning of the valve. When assembled, valves manufactured in accordance with this standard shall be well fitted and shall operate smoothly. All like parts of valves of the same model and size produced by the same manufacturer shall be interchangeable.
- x. All castings shall be clean and sound, without defects that will weaken their structure or impair their service. Plugging, welding, or repairing of cosmetic defects is allowed. Repairing of structural defects is not allowed. Repaired valves shall comply with the testing requirements of this specification after repairs have been made. Repairs within the bolt circle of any flange face are not allowed.
- y. All gate valves shall be hydrostatically tested with twice the specified rated pressure applied to one side of the gate and zero pressure applied to the other side. The test is to be made in each direction across the gate. All tests are to be performed at the manufacturer's plant.
- z. All gate valves shall be operated through a complete cycle in the position for which it was designed to ensure free and proper functioning of all parts in the intended manner. Any defects in workmanship shall be corrected and the test repeated until satisfactory performance is demonstrated. All tests are to be performed at the manufacturer's plant.
- aa. A hydrostatic test pressure equal to twice the rated working pressure of the valve shall be applied to all assembled valves with the gates in the open position. The test shall show no leakage through the metal, pressure containing joints, or stem seals. All tests are to be performed at the manufacturer's plant.

RESILIENT-SEATED GATE AND TAPPING VALVES
SPECIFICATION NUMBER 21-02

- bb. A test shall be made from each direction at rated working pressure to prove the sealing ability of each valve from both directions of flow. The test shall show no leakage through the metal, pressure containing joints, or past the seat. All tests are to be performed at the manufacturer's plant.
- cc. Markings shall be cast on the bonnet or body of each valve and shall show the manufacturer's name or mark, the year the valve casting was made, the size of the valve, and the designation of working water pressure, for example "200 W".
- dd. The San Antonio Water System may, at no cost to the manufacturer, subject random valves to testing by an independent laboratory for compliance with these standards. Any visible defect or failure to meet the quality standards herein will be grounds for rejecting the entire order and removal of the manufacturer from the attached approval list.
- ee. The attached qualified product list identifies specified manufacturers that are approved.

4. **WORKMANSHIP**

- a. All parts of the resilient seat gate valve shall be designed and manufactured to the tolerances specified in ANSI/AWWA C509-01 or latest revision thereof and this specification.
- b. All parts of the resilient seat gate valve manufactured by a given manufacturer shall be interchangeable with like parts from another resilient seat gate valve of the same model and size and by the same manufacturer.
- c. All interchangeable parts shall conform to their required dimensions and shall be free from defects that could prevent proper functioning of the valve.
- d. All castings shall be clean and sound, without defects that will weaken their structure or impair their service. Plugging, welding, or repairing of cosmetic defects is allowed. Repairing of structural defects is not allowed. Repaired valves shall comply with the testing requirements of this specification after repairs have been made. Repairs within the bolt circle of any flange face are not allowed.

RESILIENT-SEATED GATE AND TAPPING VALVES
SPECIFICATION NUMBER 21-02

- e. The resilient seat gate valves shall be well fitted.
- f. Operation of the resilient seat gate valve shall be smooth.
- g. All parts shall be free of structural defects.
- h. The resilient seat gate valve shall be watertight.

5. **PAINTING**

- a. All exterior and interior surfaces of the valve shall be coated with epoxy, N.S.F. 61 certified. The epoxy shall have a nominal dry film thickness of 8 mils, and shall be in accordance with AWWA C550, latest revision.
- b. Coating shall be as close to holiday free as is technologically possible.

6. **TESTING**

- a. Hydrostatic Test: Hydrostatic Test shall be performed on the valve in accordance with Section 6.1 Proof of Design Testing of ANSI/AWWA C509-01 or latest revision thereof.
- b. Torque Test: Torque Test for prototype valves shall be performed on the valve in accordance with Section 6.1 Proof of Design Testing of ANSI/AWWA C509-01 or latest revision thereof.
- c. Leakage Test: Leakage Test shall be performed on the valve in accordance with Section 6.1 Proof of Design Testing of ANSI/AWWA C509-01 or latest revision thereof.
- d. Pressure Test: Pressure Test shall be performed on the valve in accordance with Section 6.1 Proof of Design Testing of ANSI/AWWA C509-01 or latest revision thereof.
- e. Operation Test: Operation Test shall be performed on the valve in accordance with Section 6.2 Production Testing of ANSI/AWWA C509-01 or latest revision thereof.

RESILIENT-SEATED GATE AND TAPPING VALVES
SPECIFICATION NUMBER 21-02

- f. Shell Test: Shell Test shall be performed on the valve in accordance with Section 6.2 Production Testing of ANSI/AWWA C509-01 or latest revision thereof.
- g. Seat Test: Seat Test shall be performed on the valve in accordance with Section 6.2 Production Testing of ANSI/AWWA C509-01 or latest revision thereof.
- h. An Affidavit of Compliance certifying that all required tests have been performed shall be provided in accordance with Section 6.3 Affidavit of Compliance of ANSI/AWWA C509-01.
- i. The Affidavit of Compliance, the results of ASTM testing procedures and requirements for materials, Manufacturer's Quality Assurance Program, and the records of all tests performed on the valve shall be kept and provided by the supplier/manufacturer in a single hard cover bound notebook with the bid or with the shipping documents and shall be approved by the San Antonio Water System.

7. **QUALITY ASSURANCE**

- a. Manufacturers shall have an ASME or I.S.O. 9001 registered commercial quality system or is in the process of achieving this certification by June 2001. Noncompliance to this registered commercial quality system requirement by June 2001 will result in removal of the manufacturer's product from Attachment I of this specification. If on receipt of resilient seat gate valves they are found to be non-compliant the manufacturer shall replace the defective resilient seat gate valves according to resilient seat gate valve size with a resilient seat gate valve that meets the San Antonio Water System's specifications. The defective resilient seat gate valve will be returned to the manufacturer, freight collect, and the manufacturer shall replace the resilient seat gate valve, freight prepaid. If San Antonio Water System audits, product inspection and performance data review in accordance with these specifications determine excessive resilient seat gate valve non-compliance, the manufacturer will be subject to removal by the Products Standards Committee. If the resilient seat gate valve becomes defective during the manufacturer's specified warranty period a San Antonio Water System quality assurance and manufacturer review will

RESILIENT-SEATED GATE AND TAPPING VALVES
SPECIFICATION NUMBER 21-02

ensue. If the review determines manufacturing non-conformance the manufacturer shall replace the resilient seat gate valve according to size with a resilient seat gate valve that meets the San Antonio Water System's specifications. The defective resilient seat gate valve removed from the field will be returned to the manufacturer, freight collect, and the manufacturer shall replace the resilient seat gate valve, freight prepaid. If the non-conformance product amounts are excessive and result in increased product replacement by San Antonio Water System field staff the manufacturer may be subject to time and material charges.

8. **REFERENCES**

- a. American National Standards Institute and American Water Works Association Standard C509-01 (ANSI/AWWA C509-01).
- b. Manufacturers Standardization Society MSS SP-60.

APPROVED MANUFACTURER

PRODUCTS LIST

Sizes Three through Twelve Inch

Manufacturer

Model

American Flow Control	Series 500
Clow Valve Company	2640
Kennedy Valve	KS - FW
M&H Valve Company	4067
Mueller Company	2360 Series Gate Valve
United States Pipe & Foundry Company	A-USPO

Sizes Sixteen through Twenty-Four Inch

Manufacturer

Model

United States Pipe & Foundry Company	A-USPO
--------------------------------------	--------

Previous Revised/ Rnc.

Oct 2008
Aug 2004
April 2000

SPECIFICATIONS FOR AIR RELEASE, VACUUM & COMBINATION AIR

VALVES FOR WATER SERVICE

REVISED DECEMBER 2011

1. **SCOPE**

This specification covers automatic valves installed on water mains to vent accumulated air under system pressure, and to provide air exhaust during initial fill or to prevent a vacuum during draining or water column separation of the system.

2. **GENERAL REQUIREMENTS**

- a) Valves furnished under this specification shall conform to ANSI/NSF Standard 60 for direct additives and ANSI/NSF Standard 61 for indirect additives. Cast Iron Valve Body and cover shall be in accordance with ASTM A48-35 or ASTM A126 class B. Non-Metallic Valve Body shall be fabricated from fiberglass reinforced nylon. Inlet sizes through 2 inches shall be screwed (NPT). Pipe sizes 3" and above shall have flanged inlets (125# ASNSI B 16.1). A protective hood or cowl shall be installed on the outlet of flange-bodied valves.
- b) Metallic Internal seat trim float arm and pivot pin shall be stainless steel type 303, 304 or 316. Metallic Floats shall be stainless steel ASTM A 240. Other stainless steel metal internal parts shall be stainless steel ASTM A240 or ASTM A276.
- c) Non-metallic floats shall be foamed polyethylene with stainless steel type 316 fasteners.
- d) Valves requiring Internal seats or orifice buttons shall be Buna-N rubber compounded for water service. For valves requiring cover gaskets, the cover gasket shall be composition type, equal to Armstrong CS-231, Garlock 3000, or Lexide NK-511. If an O-Ring is used to seal the cover, it shall be on NSF 61 certified rubber. Cover bolts shall be alloy steel. Rolling seals shall be furnished for non-metallic valves 2" and below.
- e) Valve body shall have a test pressure rating of 300 psi and working pressure rating of 150 psi.

San Antonio Water System Material Standard Specifications

AIR RELEASE, VACUUM & COMBINATION AIR VALVES FOR

WATER SERVICE SPECIFICATION NUMBER 29-01

REVISED DECEMBER 2011

3. GENERAL OPERATION REQUIREMENTS

- a) The air release valve shall be designed to vent accumulated air automatically. The outlet orifice shall be properly sized to facilitate valve operation at pressures up to 150 psi. The air release valve shall be simple-lever, compound-lever, ball and orifice or rolling seal depending upon volume requirements and the design of the valve.
- b) The air and vacuum valve shall be designed with the inlet and outlet of equal cross-sectional area where applicable. The valve shall be capable or automatically allowing large quantities of air to be exhausted during the filling cycle an also capable of automatically allowing air to re-enter the system to prevent a negative pressure at water column separation or during the draining cycle. The float shall be guided to minimize premature closure by air and to provide proper alignment for normal closure by floating on the water surface.
- c) Combination air and vacuum relief valves shall provide for both automatic air release under system pressure and to allow air movement during filling or draining operations or water column separation. The combination valve may be housed in a single casting. The housing shall be designed to incorporate conventional or kinetic flow principles to properly vent the air without premature closure. Flanged sized (4 inch and larger) may be furnished in a dual housing. When dual casings are used a bronze manual isolation valve shall be installed if indicated by the manufacturer. This will allow the air release valve to be serviced when the system is under pressure. Field service of the valve may also be performed by closing the isolation valve between the air valve and the pipe connection.

4. TESTS

The San Antonio Water System may, at no cost to the manufacturer, subject random valves to testing by an independent laboratory for compliance with these standards. Any visible defect or failures to meet the quality standards herein will be grounds for rejecting the entire order.

5. QUALITY ASSURANCE

The manufacturers shall provide certification that products furnished under this specification are manufactured in an ISO 9001 certified facility or documentation from an accredited facility that ISO 9001 certification is in process.

San Antonio Water System Material Standard Specifications

AIR RELEASE, VACUUM & COMBINATION AIR VALVES FOR

WATER SERVICE SPECIFICATION NUMBER 29-01

REVISED DECEMBER 2011

6. The following qualified products list identifies specific manufactured items by catalog number that are approved.

Approved Manufacturers and Models:

A. Air Release Valves (Inlet x Orifice)

<u>Manufacturer</u>	<u>1"NPT x 3/16"</u>	<u>2" NPT x 3/16"</u>
Apco Valve Company	200A	200A
G.A. Industries, Inc. (Empire)	920	920
Multiplex Mfg. Co. (Crispin)	PI-10	PL-10A
Val-Matic Mfg. Co.	38	38
PowerSeal Corporation	5401-D	5401-E
ARI Flow control	S-050 1T	D-040 2T

B. Air & Vacuum Valves (Inlet x Orifice)

<u>Manufacturer</u>	<u>2" NPT x 3/16"</u>	<u>4" flg. with cowl</u>
Apco Valve Company	144	152
G.A. Industries, Inc. (Empire)	930	930-C
Multiplex Mfg. Co. (Crispin)	AL20	AL41
Val-Matic Mfg. Co.	102	104
PowerSeal Corporation	5402-B	5402-D
ARI Flow Control	D-040 2T	K060 C-HF

San Antonio Water System Material Standard Specifications

AIR RELEASE, VACUUM & COMBINATION AIR VALVES FOR

WATER SERVICE SPECIFICATION NUMBER 29-01

REVISED DECEMBER 2011

Approved Manufacturers and Models:

C. Combination Air Valves (Inlet x Orifice)

<u>Manufacturer</u>	<u>1"NPT x 5/64"</u>	<u>2" NPT x 3/32"</u>	<u>4"flg. x 3/32 w/ cowl</u>
Apco Valve Company	143C	145C	149C
G.A. Industries, Inc. (Empire)	945 (1" NPT)	945	960C
Multiplex Mfg. Co. (Crispin)	U10	UL20 (1/4")	UL41 (1/4")
Val-Matic Mfg. Co.	201C	202C	204C
PowerSeal Corporation	5403-A	5403-B	5403-D
ARI Flow Control	D-040 2T	D-040 D-060 C-HF	D-060 C-HF

San Antonio Water System Material Standard Specifications

AIR RELEASE, VACUUM & COMBINATION AIR VALVES FOR

WATER SERVICE SPECIFICATION NUMBER 29-01

REVISED DECEMBER 2011

D. Air and Vacuum Valves

Manufacturer: Vent-O-Mat

Series: RBX (water)

<u>1" NPT</u>	<u>2" NPT</u>	<u>3" Flange</u>	<u>4" Flange</u>	<u>6" Flange</u>	<u>8" Flange</u>
RBX 2521	RBX 2521	RBX 1631	RBX 1631	RBX 1631	RBX 1631
RBX 4021	RBX 4021	RBX 2531	RBX 2531	RBX 2531	RBX 2531
RBXb 2521	RBXb 2521	RBX 4031	RBX 4031	RBX 4031	RBX 4031
RBXb 4021	RBXb 4021	RBXb 1631	RBXb 1631	RBXb 1631	RBXb 1631
RBXv 2521	RBXv 2521	RBXb 2531	RBXb 2531	RBXb 2531	RBXb 2531
RBXv 4021	RBXv 4021	RBXb 4031	RBXb 4031	RBXb 4031	RBXb 4031
		RBXv 1631	RBXv 1631	RBXv 1631	RBXv 1631
		RBXv 2531	RBXv 2531	RBXv 2531	RBXv 2531
		RBXv 4031	RBXv 4031	RBXv 4031	RBXv 4031

San Antonio Water System Material Standard Specifications

AIR RELEASE, VACUUM & COMBINATION AIR VALVES FOR

WATER SERVICE SPECIFICATION NUMBER 29-01

REVISED DECEMBER 2011

Manufacturer: Vent-O-Mat

Series: RGX (sewage)

<u>2" NPT Flange</u>	<u>3" Flange</u>	<u>4" Flange</u>	<u>6" Flange</u>	<u>8" Flange</u>
RGX 1021	RGX 1021	RGX 1021	RGX 1031	RGX 1031
RGX 1031	RGX 1031	RGX 1031	RGX 1631	RGX 1631
RGX 1621	RGX 1621	RGX 1621	RGXb1031	RGXb 1031
RGX 1631	RGX 1631	RGX 1631	RGXb 1631	RGXb 1631
RGXb 1021	RGXb 1021	RGXb 1021	RGXv 1031	RGXv 1031
RGXb 1031	RGXb 1031	RGXb 1031	RGXv 1631	RGXv 1631
RGXb 1621	RGXb 1621	RGXb 1621		
RGXb 1631	RGXb 1631	RGXb 1631		
RGXv 1021	RGXv 1021	RGXv 1021		
RGXv 1031	RGXv 1031	RGXv 1031		
RGXv 1621	RGXv 1621	RGXv 1621		
RGXv 1631	RGXv 1631	RGXv 1631		

Previous Specification Date:

JANRUARY 1991

AUGUST 1992

DECEMBER 2005

DECEMBER 2011

San Antonio Water System Material Standard Specifications

95-10

SPECIFICATIONS FOR PIPE JOINT RESTRAINT SYSTEMS

REVISED MAY 2023

1. SCOPE

This specification covers pipe joint restraint systems to be used on domestic water mains for PVC C-900 pipe sizes 4-inch through 24-inch diameter and for Ductile Iron pipe sizes from 4-inch through 24-inch diameter. Joint restraint systems are classified as “compression, “mechanical joint” or non- metallic restrained joint “ for the specific type of pipe joint to be restrained.

2. GENERAL REQUIREMENTS

- a) Underwriter Laboratories (U.L) and Factory Mutual (FM) certifications are required on all restraint systems.
- b) Unless otherwise noted, restraint systems to be used on PVC C-900 pipe shall meet or exceed A.S.T.M. Standard F1674-96, “Standard Test Methods for Joint Restraint Products for Use with PVC Pipe,” or the latest revision thereof. Restraint systems used on ductile pipe shall meet or exceed U.L. Standard 194
- c) Non-metallic restrained joint pipe and couplings shall be utilized specifically for C-900 PVC pipe and fittings in sizes 4”-12”.
- d) Each restraint system shall be packaged individually and include installation instructions.

3. SPECIFIC REQUIREMENTS

A. Restrainer for PVC C-900 & Ductile Iron Push-on Type Connections:

1. Pipe restraints shall be utilized to prevent movement for push-on D.I. or PVC (C900) (compression type) bell and spigot pipe connections or where a flexible coupling has been used to join two sections of plain- end pipe D.I. or PVC (C900). The restrainer may be adapted to connect a plain end D.I. or PVC pipe to a ductile iron mechanical joint (MJ) bell fitting. The restrainer must not be directionally sensitive.

San Antonio Water System Material Standard Specifications

SPECIFICATIONS FOR PIPE JOINT RESTRAINT SYSTEMS

REVISED MAY 2023

2. The pipe shall be restrained by a split retainer band. The band shall be cast ductile iron, meeting or exceeding ASTM A536-80, Grade 65-45-12. The inside face or contact surface of the band shall be of sufficient width to incorporate cast or machined non-directionally sensitive serration to grip the outside circumference of the pipe. The serration shall provide full (360 degrees) contact and maintain pipe roundness and avoid any localized points of stress. The split band casting shall be designed to “bottom-out” before clamping bolt forces (110ft-lb minimum torque) can over-stress the pipe, but will provide full non-directionally sensitive restraint at the rated pressures.

3. Bolts and nuts used to attach the split retainer ring shall comply with ANSI B 18.2/18.2.2, SAE Grade 5. Tee-bolts, nuts and restraining rods shall be fabricated from high-strength, low-alloy steel per AWWA C111-90.

4. The split ring type non-directionally sensitive restrainer system shall be capable of a test pressure twice the maximum sustained working pressure listed in section D and be for both D.I. and/or PVC C900.

5. Restraint systems sizes six through twelve inches shall be capable of use for both ductile iron and/or PVC C900.

6. The restraint system may consist of two types: the two split retainer rings and for new construction use only the one split and one solid cast backup ring.

B. Compression Ring Fitting Restrainer for Ductile Iron Pipe & PVC C-900.

1. Compression ring with follower gland type of restrainer may be utilized in conjunction with Mechanical Joint (MJ) bell end ductile iron pipe fittings for restraining PVC C-900 and ductile iron pipe.

2. The system shall utilize a standard MJ gasket with a color-coded compression ring and replacement gland conforming to ASTM A 536-80, Grade 65-45-12.

San Antonio Water System Material Standard Specifications

SPECIFICATIONS FOR PIPE JOINT RESTRAINT SYSTEMS

REVISED MAY 2023

3. Standard MJ fitting Tee-bolts and nuts shall be fabricated from high strength steel conforming to AWWA C111/A21.11-90 and AWWA C153/A21.53-88.
4. Standard MJ gasket shall be virgin SBR meeting ASTM D-2000 3 BA 715 or 3 BA 515.
5. The restraint system shall be capable of a test pressure twice the maximum sustained working pressure listed in section D.

C. Non-metallic restrained joint pipe and couplings for PVC C-900 Type Connections:

1. Gasketed restrained coupling connections shall join two sections of factory grooved PVC (C900) pipe. The restrainer coupling or must not be directionally sensitive.
2. The coupling shall incorporate twin elastomeric sealing gaskets meeting the requirements of ASTM F-477 and shall be DR-18 Class 200 C-900 PVC in all applications, meeting or exceeding the performance requirements of AWWA C-900, latest revision. The inside face or contact surface of the coupling connection shall be of sufficient width to incorporate a factory machined non-directionally sensitive groove in both pipe and coupling to grip the outside circumference of the pipe. The couplings shall provide full (360 degrees) contact and maintain pipe roundness and avoid and localized points of stress. The coupling shall be designed with an internal stop to align the precision-machined grooves in the coupling and pipe prior to installation of a non-metallic thermoplastic restraint spleen, and will provide full non-directionally sensitive restraint at the rated pressures.
3. High-strength flexible thermoplastic spleens shall be inserted into mating precision –machined grooves in the pipe and coupling to provide full non-directional restraint with evenly distributed loading.

San Antonio Water System Material Standard Specifications

SPECIFICATIONS FOR PIPE JOINT RESTRAINT SYSTEMS

REVISED MAY 2023

4. The non-metallic restrained joint pipe and couplings for PVC C-900 type non-directionally sensitive restrainer system shall be capable of a test pressure twice the maximum sustained working pressure listed in Section D and be for PVC (C900) pipe sizes four through twelve inch.

5. Non-metallic restrained joint pipe and couplings for PVC C-900 restrained systems sizes four through twelve inches shall be capable of use for Class 200 (DR 18).

6. The non-metallic restrained joint pipe and couplings for PVC C-900 restraint system shall consist of a pipe and couplings system produced by the same manufacturer meeting the performance qualifications of Factory Mutual (FM) and Underwriters Lab (UL).

D. Fitting Restraint for Ductile Iron Pipe (Only):

1. Radial bolt type restrainer systems shall be limited to ductile iron pipe in conjunction with Mechanical Joint (MJ) bell end pipe of fittings. The system shall utilize a standard MJ gasket with a ductile iron replacement gland conforming to ASTM A 536-80. The gland dimensions shall conform to Standard MJ bolt circle criteria.

2. Individual wedge restrainers shall be ductile iron heat treated to a minimum hardness of 370 BHN. The wedge screws shall be compressed to the outside wall of the pipe using a shoulder bolt and twist-off nuts to insure proper actuating of the restraining system.

3. Standard MJ fitting Tee-bolts and nuts shall be high strength steel conforming to AWWA C111/A21.11-90 and C153/A21.53-88.

4. Standard MJ gasket shall be virgin SBR meeting ASTM D-2000 3 BA 715 or 3 BA 515.

San Antonio Water System Material Standard Specifications

SPECIFICATIONS FOR PIPE JOINT RESTRAINT SYSTEMS

REVISED MAY 2023

E. Maximum Sustained Working Pressure Requirements:

<u>Nominal Diameter</u>	<u>PVC C-900 / C-905</u>		<u>Ductile Iron</u>
4 & 6 inch	200 p.s.i		350 p.s.i
8 inch	200 p.s.i		250 p.s.i
10 & 12 inch	200 p.s.i		200 p.s.i
14 & 16 inch	200 p.s.i	235 p.s.i	200 p.s.i.
20 & 24 inch	200 p.s.i	235 p.s.i	200 p.s.i

4. TESTS:

The San Antonio Water System may, at no cost to the manufacturer, subject random joint restraint system products to testing by an independent laboratory for compliance with these standards. Any visible defect of failure to meet the quality standards herein will be ground for rejecting the entire order.

5. PRODUCT LIST:

The attached qualified product list identifies specified manufacturers models approved for installation in SAWS water distribution systems.

Approved Manufacturers and Models:

<u>A. Slip on Joint System</u>	<u>PVC C-900</u>	<u>Ductile Iron D.I.</u>	<u>16" Above</u>
Ford/Uni-Flange	1390C	1390C	1490
EBBA Iron Sales, Inc	1500	1700	1700
Romac Industries, Inc. 4-12-inch	Model 611		
Star Pipe Products	1100G2/1100	1100	
Tyler Union	3000PP		
Sigma Corporation	PV-LOK	PV-LOK	SLDEH
	(PVP)/PTP	(PVP)/PTP/	
		SLDH	
SIP Industries	EZPVCP	EZDPTP	

San Antonio Water System Material Standard Specifications

SPECIFICATIONS FOR PIPE JOINT RESTRAINT SYSTEMS

REVISED MAY 2023

B. Compression Ring Systems:	PVC C-900	Ductile Iron
Romac Industries, Inc.	GripRing-D1	GripRing-D1

San Antonio Water System Material Standard Specifications

SPECIFICATIONS FOR PIPE JOINT RESTRAINT SYSTEMS

REVISED MAY 2023

C. Non-Metallic Restrained Joint Pipe and Couplings for PVC C-900 RJ Type Connections:

Certain Teed Corporation, Certa-Lok C-900/RJ
(4" – 12")

D. Fitting Restraint (MJ): **PVC C-900** **Ductile Iron**

EBBA Iron Sales, Inc.	2000 PV	Megalug1100
Romac Industries, Inc.	Not Approved	Not Approved
Ford/Uni-Flange	UFR-1500-C 4"- 24"	Series 1400
StarPipe Products	Stargrip 4000	Not Approved
Sigma Corporation	One Lok SLC	One Lok SLD
Tyler Union	TUFG RIP 2000 F	TUFG RIP 1000F

E. Restrained Flange Adapters **PVC C-900** **Ductile Iron**

EBBA Iron Sales, Inc	2100 Megaflange (4-20")	2100 Megaflange (4-24")
Ford/Uni-Flange		400 (8-12"),420 (4-12")

Previous Specification Date:

JANRUARY 1998
APRIL 2002
FEBRUARY 2004
APRIL 2004
AUGUST 2004
MARCH 2005
OCTOCER 2005
OCTOBER 2006
DECEMBER 2011
APRIL 2014

SECTION 33111

PVC WATER MAIN (SDR21)

PART I – GENERAL

1.01 SCOPE

- A. This section covers the specifications for PVC potable water pipe 4” to 16” in diameter.
- B. Related Work:
 - 1. SAWS
 - a. SAWS Construction Specification 812 Water Main Installation
 - b. SAWS Construction Specification 836 Grey Iron and Ductile Iron Fittings
 - c. SAWS Construction Specification 839 Anchorage Thrust Blocking and Joint Restraint

1.02 PRODUCT DELIVERY, HANDLING, AND STORAGE

- A. Certification:
 - 1. Submit manufacturer's certification that products meet requirements of referenced specifications, in accordance with this section.
- B. Shop Drawings
 - 1. Submit drawings and data showing details of joints, gasket material and pipe length.

1.03 SUBMITTALS

- A. Do not damage the pipe and fittings by impact, bending, compression or abrasion during handling and storage.
- B. Store pipe on a flat surface which provides even support for the barrel with bell ends overhanging.
- C. Do not stack pipe higher than 5 feet.
- D. Do not use pipe and fittings stored in direct sunlight for periods in excess of six months.
- E. Ship rubber gaskets in cartons and store in clean area away from grease, oil, ozone producing electric motors, heat, and the direct rays of the sun.
- F. Use only nylon protected slings or bands to handle pipe. Do not use hooks or bare cables.

PART 2 – PRODUCTS

2.01 POLYVINYL CHLORIDE (PVC) PRESSURE PIPE (4” TO 16”)

- A. Reference Standard:

- B. Pressure Class: SDR21 (200 PSI) unless otherwise indicated on drawings
- C. Joints: Bell ends with elastomeric gaskets
- D. Fittings: Ductile Iron, Cement Mortar Lined
- E. Mechanical Joints:
 - 1. Ductile Iron, ANSI A21.53/AWWA C153 & C110
 - 2. Gaskets, ANSI A21.11/AWWA C111
- F. Flanged Joints
 - 1. Ductile Iron ANSI A21.10/AWWA C110
 - 2. Drilling: ASA - B16.1, Class 125
- G. Polyethylene Encasement
 - 1. AWWA C-105
- H. Anodes
 - 1. 17 lb. Magnesium Anode to be Cad welded to each fitting

PART 3 – EXECUTION

3.01 INSPECTION

- A. Examine the pipe for cracks, dents, abrasions, or other flaws prior to installation.
- B. Allow access for the marking of rejected pipe. Rejected pipe will be plainly marked by the Engineer, Owner or their respective representative by painting colored spots on the inside wall of the pipe and on the top outside wall of the pipe, or by other means that aforementioned parties will communicate to Contractor. The painted spots will be no larger than 4 in. in diameter. The rejected pipe will not be defaced in any other manner
- C. Mark rejected pipe and remove from site

3.02 CUTTING PIPE

- A. Cut the pipe square with saw or pipe cutter designed specifically for the material
- B. Bevel the end in accordance with the manufacturer's recommendations

3.03 CONSTRUCTION

- A. PVC (SDR21) mains shall be laid to the depth and grades shown in the contract documents.
- B. The pipe shall be laid by inserting the spigot end into the bell flush with the insertion line or as recommended by the manufacturer.
- C. At no time shall the bell end be allowed to go past the "insertion line".
- D. A gap between the end of the spigot, and the adjoining pipe is necessary to allow for expansion and contraction

- E. Deflection of PVC (SDR21) pipe shall be limited to 1 degree of the manufacturers recommended deflection.
1. Changes in direction of PVC pipe shall only be use of fittings or by deflecting straight pipe sections at joints.
 2. Longitudinal bending of pipe is not allowed.
 3. Deflection of pipe at fittings is not allowed.
 4. Deflection of straight pipe sections shall not exceed 1 degree at each joint (even if joint restraint devices are installed)
 5. Install pipe restraints in accordance with SAWS 839 Anchorage Thrust Blocking and Joint Restraint.

3.04 JOINT INSTALLATION FOR PVC PIPE

A. Push-On-Joints:

1. Clean the inside of the bell and the outside of the spigot to remove dirt, oil, excess coating, and other foreign matter.
2. Insert the gasket.
3. Apply a thin film of lubricant to either the inside surface of the gasket, the spigot end of the pipe, or both.
4. Do not permit the joint surface to come into contact with the ground.
5. Assure that pipe is marked with a depth mark before assembly to assure the spigot end is inserted the full depth of the joint.
6. Complete the joint making certain the spigot is inserted to the depth mark.
7. Do not use excessive force in joining the pipe.

B. Mechanical Joints:

1. Remove dirt, oil, grit, excess coating, and other foreign matter from the inside of the bell and the outside of the spigot.
2. Apply a thin film of lubricant to the inside of the bell, the outside of the spigot and the gasket.
3. Tighten nuts alternately on opposite sides of the pipe to produce equal pressure on all parts of the gland.
4. Use a torque limiting wrench and do not exceed the following maximum torque values:

<u>Bolt Size</u>	<u>Torque (Ft./Lbs.)</u>
5/8"	--
3/4"	60 - 90
1"	70 - 100
1-1/4"	90 - 120

5. Holes in mechanical joint bells shall straddle the top (or side for vertical piping) centerline.
6. Secure tube type polyethylene encasement on all fittings by taping to insert pipe.

C. Flanged Joints:

1. Extend pipe completely through screwed-on flanges
2. Machine finish the pipe and end flange face in a single operation
3. Eliminate any restraints on the pipe which would prevent uniform gasket compression or cause unnecessary stress in the flanges.
4. Do not assemble mechanical connections until all flanged joints affected thereby have been tightened.
5. Alternately tighten bolts spaced on opposite sides of the pipe to assure uniform gasket compression.
6. Holes in flanges shall straddle the top (or side for vertical piping) centerline.
7. Secure tube type polyethylene encasement on all fittings by taping to insert pipe.

D. Mechanical Couplings:

1. Clean and smooth pipe ends.
2. 1/4 inch to less than one inch space between pipe ends.

END OF SECTION

SECTION 33120

SMALL DIAMETER PIPE, FITTINGS, AND APPURTENANCES

PART 1 – GENERAL

1.01 DESCRIPTION

A. Work Included:

1. This section covers small diameter piping systems, fittings, appurtenances, pipe insulation, pipe support systems, and installation equipment and requirements.

B. Related Work:

1. SAWS ITEM NO. 804 Excavation Trenching and Backfill

1.02 REFERENCED STANDARDS

- A. Products intended to convey or dispense water for human consumption contained in this specification shall be compliant with, but not limited to, the U.S. Safe Drinking Water Act (SDWA), requirements of authorities having jurisdiction, and NSF 61/NSF 372, or to be certified in compliance with NSF 61/NSF 372 by an American National Standards Institute (ANSI)-accredited third-party certification body that the weighted average lead content at wetted surfaces is less than or equal to 0.25 percent.

1.03 SUBMITTALS

A. Certification:

1. Submit manufacturer's certification that products meet requirements of referenced specifications.

B. Shop Drawings:

1. Submit drawings and data showing details of joints, gasket material, pipe length, fittings, appurtenances.

1.04 PRODUCT DELIVERY, STORAGE AND HANDLING

- A. Ship and stack pipe in accordance with manufacture's recommendations.
- B. Do not drop or damage pipe through impact.
- C. Ship and store rubber gaskets in cartons away from grease, oil, sunlight, and ozone producing motors.
- D. Store pipe on a flat surface which provides even support for the barrel with bell ends overlapping.
- E. Ship and store, solvents, adhesives, and other volatile products away from open flames and in accordance with manufacturer specifications.
- F. Do not stack pipe higher than 5 feet.
- G. Use only nylon protected slings or bands to handle pipe. Do not use hooks or bare cables.

PART 2 – PRODUCTS

2.01 POLYVINYL CHLORIDE (PVC) PRESSURE PIPE (3/4" ≤ 3")

A. Polyvinyl Chloride (PVC) Pressure Pipe

1. Referenced Standard: ASTM D2241
2. Dimension Ratio: SDR 21

2.02 STEEL PIPE

A. Steel Pipe (<6")

1. Reference Standard: AWWA C-220
2. Schedule: Schedule 80

2.03 SOLVENT CEMENTS FOR JOINING PVC PIPING

A. Include Primer in accordance with ASTM F656 and Cement in accordance with ASTM D2564 Provide Oatey; PVC Cement and Primer or comparable product by one of the following:

1. Engineer approved equal

B. Cement Properties:

1. Color: Clear
2. Viscosity: Heavy Duty
3. Type: Fast Set

C. Primer Properties:

1. Color: Clear
2. Type: NSF Listed
3. Grade: Industrial

D. Solvent cement shall have a VOC content of 510 g/L or less.

E. Adhesive primer shall have a VOC content of 550 g/L or less.

2.04 THREAD TAPE & SEALANT

A. Food grade commercial duty thread sealant and/or tape only.

2.05 PLASTIC TO METAL TRANSITION FITTINGS

A. Manufacturers: Subject to compliance with requirements, provide products by one of the following:

1. Charlotte Pipe and Foundry Company.
2. Harvel Plastics, Inc.
3. Sioux Chief Manufacturing Company, Inc.
4. Spears Manufacturing Company.
5. Uponor.
6. Engineer approved equal.

B. Description:

1. PVC one-piece fitting with manufacturer's Schedule 80 equivalent dimensions.
2. One end with threaded brass insert and one solvent-cement-socket or threaded end.

2.06 PLASTIC TO METAL TRANSITION UNIONS

A. Manufacturers: Subject to compliance with requirements, provide products by one of the following:

1. Colonial Engineering, Inc.
2. NIBCO INC.
3. Spears Manufacturing Company.
4. Engineer approved equal

B. Description:

1. PVC four-part union.
2. Brass or stainless-steel threaded end.
3. Solvent-cement-joint or threaded plastic end.
4. Rubber O-ring.
5. Union nut.

2.07 Y-PATTERN STRAINERS

A. Provide a Titan Flow Control Inc, YS55-BZ or comparable product by one of the following:

1. WATTS.
2. Zurn Industries, LLC.
3. Engineer approved equal

B. End Connections: Threaded

C. Pressure Rating: 200 psig at 150°F minimum unless otherwise specified

D. Body: ASTM B584 Bronze

E. Strainer Screen: Stainless Steel

F. Perforation Size:

1. NPS 1/4 to NPS 2: 20 Mesh

G. Drain: ASTM B584 Bronze NPT plug, installed

2.08 DIRECT MOUNTED, METAL CASE, DIAL TYPE PRESSURE GAUGES

A. Manufacturers: Subject to compliance with requirements, provide products by one of the following:

1. Ashcroft Inc
2. Terice, H. O. Co.
3. Watts Regulator Co.; a div. of Watts Water Technologies, Inc.
4. Weiss Instruments, Inc.
5. Engineer approved equal

B. Standard: ASME B40.100.

C. Case: Liquid-filled, Sealed, Solid-front, pressure relief, cast aluminum or drawn steel, 4-1/2-inch nominal diameter.

D. Pressure-Element Assembly: Bourdon tube unless otherwise indicated. Match pressure connection size in first subparagraph below with gage attachment size.

1. Pressure Connection: Brass, with NPS 1/4 or 1/2, ASME B1.20.1 pipe threads and bottom-outlet type unless back-outlet type is indicated.
2. Movement: Mechanical, with link to pressure element and connection to pointer.
3. Dial: Nonreflective aluminum with permanently etched scale markings graduated in psi

4. Pointer: Dark-colored metal.
5. Window: Glass or Plastic
6. Ring: Brass
7. Accuracy: Grade A, plus or minus 1 percent of middle half of scale range.

2.09 CHECK VALVES (<3")

A. Provide a Apollo Valves; Aalberts-IPS: 164T Series or comparable product by one of the following:

1. A.Y. McDonald Mfg. Co.
2. Crane Valves; a Crane Co. brand.
3. Hammond Valve.
4. Lance Valves.
5. Legend Valve & Fitting, Inc.
6. Milwaukee Valve Company.
7. NIBCO INC.
8. Powell Valves.
9. Stockham; a Crane Co. brand.
10. Engineer approved equal

B. Description:

1. Standards: MSS SP-80, Type 3
2. CWP Rating: 300 psig (2070 kPa).
3. Body Design: Horizontal flow.
4. Body Material: ASTM B62, bronze.
5. Ends: Threaded
6. Disc: Bronze.

2.10 SOLENOID VALVES

A. Provide a ASCO Valve, Inc.; 8210 Series or comparable product by one of the following:

1. Engineer Approved Equal

B. Description:

1. Action: Either normally open or normally closed in the event of electrical power failure as required by the application
2. Size to close against the system pressure.
3. Manual override capable
4. Heavy-duty assembly
5. Body: Brass or stainless steel
6. Seats and Discs: NBR or PTFE
7. Solenoid Enclosure: NEMA 250, Type 4

2.11 BRASS BALL VALVES, ONE PIECE, THREADED ENDS (1/8" ≤ 4")

A. Provide a Legend Valve and Fitting, Inc.; Model T-1001NL or comparable product by one of the following:

1. KITZ Corporation.
2. Watts Water Technologies; a Watts company.
3. Engineer approved equal

B. Standards:

1. MSS SP-110
2. MSS SP-145

C. Description:

1. Body Material:
 - a. Forged brass, unless otherwise specified in plans
2. Engineer approved equal

2.12 GATE VALVES (≤ 2 ")

A. Provide a Apollo Valves; Aalberts IPS; 107T Series or comparable product by one of the following:

1. Stockham; a Crane Co. brand.
2. WATTS.
3. Engineer approved equal

B. Standards:

1. MSS SP-80, Type 2.

C. Description:

1. CWP Rating: 300 psig
2. Body Material: Bronze with integral seat and union-ring bonnet.
3. Ends: Threaded.
4. Stem: Bronze.
5. Disc: Solid wedge; bronze.
6. Packing: Asbestos free.
7. Handwheel: Bronze

2.13 PRESSURE REDUCING VALVES (PRV) (< 2 ")

A. Provide a Caleffi North America 535H Series PresCal or comparable product by one of the following:

1. Cash Acme; a division of Reliance Worldwide Corporation.
2. WATTS
3. Engineer approved equal

B. Standards:

1. ASSE 1003/CSA B356, NSF/ANSI/CAN 372 low-lead laws, as certified by ICC-ES.
2. NSF/ANSI/CAN 61, commercial hot water 180 deg F (82 deg C) as certified by ICC-ES.
3. IPC, IRC, NPC, and UPC.

C. Description:

1. Body Material: DZR EcoBrass low-lead forged brass, or engineer approved equal

2.14 FLEXIBLE ELASTOMERIC PVC PIPE INSULATION

A. Provide K-Flex USA; K-FLEX INSUL-LOCK DS or comparable product by one of the following:

1. Aeroflex USA
2. Armacell LLC

3. Engineer approved equal

B. Standards:

1. Closed-cell or expanded-rubber materials; suitable for maximum use temperature between minus 40 deg F and 220 deg F. Comply with ASTM C534/C534M, Type I for tubular materials.

C. Preformed Pipe Insulation: Type I

2.15 ADHESIVES

A. Provide K-Flex USA; K-FLEX 620 Adhesive or comparable product by one of the following:

1. Aeroflex USA.
2. Armacell LLC.
 - a. ArmaFlex 520 BLV Adhesive
3. Foster Brand; H. B. Fuller Construction Products.
4. Engineer approved equal

B. Standards:

1. Comply with MIL-A-24179A, Type II, Class I.
2. For indoor applications, use ArmaFlex 520 BLV Adhesive or Engineer approved equal adhesive that has a VOC content of 50 g/L or less when calculated according to 40 CFR 59, Subpart D (EPA Method 24).

C. Description:

1. Flame-spread index is 25 or less and smoke-developed index is 50 or less as tested in accordance with ASTM E84
2. Wet Flash Point: Below 0 deg F
3. Service Temperature Range: 40 to 200 deg F
4. Color: Black

2.16 INSULATION TAPES

A. Provide K-Flex USA; K-FLEX Seam Tape or comparable product by one of the following:

1. Ideal Tape Co., Inc., an American Biltrite Company.
2. Engineer approved equal

B. Standards:

1. Vapor-retarder tape matching field-applied PVC jacket with acrylic adhesive; suitable for indoor and outdoor applications

C. Description:

1. Width: 2 Inches
2. Thickness: 5 mils
3. Adhesion: 64 ounces/inch
4. Elongation 500%
5. Tensile Strength 18 lbf/in

2.17 PIPE MOUNTING (WALL AND FLOOR)

- A. Provide ASC Engineered Solutions 262 Strap Short pipe straps and 103 Offset Pipe Clamp or comparable products by one of the following:
 - 1. Engineer approved equal
- B. Standards:
 - 1. ANSI/MSS SP-69
 - 2. MSS SP-58 (Type 26)
- C. Description:
 - 1. Material: Carbon Steel
 - 2. Finish: Hot Dip Galvanized
 - 3. Screws or Bolts: Coordinate with structure manufacturer and/or contractor to determine proper fastening hardware

PART 3 – EXECUTION

3.01 GENERAL

- A. Do not install cracked, chipped, dented, abraded, or otherwise defective pipe or insulation.
- B. Do not apply adhesives that have passed shelf life per manufacture date.
- C. Install in accordance with manufacturer’s recommendations.
- D. Install dielectric joint, fitting, or similar accessory when joining two dissimilar metals.
- E. Unless otherwise specified, do not use flanges or unions for underground piping.
- F. Ensure all products to be installed/applied are clean and dry.
- G. If necessary, coordinate the insulation installation with the tradesman installing heat tracing. Comply with requirements for heat tracing that apply to insulation.

3.02 CUTTING PIPE

- A. PVC Pipe:
 - 1. Cut the pipe square with saw or pipe cutter designed specifically for the material.
 - 2. Bevel the end in accordance with the manufacturer’s recommendations.
- B. Steel Pipe:
 - 1. Cut pipe smooth using saws or abrasive wheels.
 - 2. Pipe shall be cut at right angles to the pipe axis or angles as needed to properly seat in fittings.
 - 3. Do not damage coating or lining by cutting
 - 4. Use threaded joints unless otherwise noted

3.03 PIPE, FITTINGS, AND APPURTENANCES

- A. See SAWS ITEM NO. 804 Excavation Trenching and Backfill
- B. Install all pipes, fittings, and appurtenances per manufacturer specification.
- C. Apply thread sealant or tape where recommended by manufacturer.

3.04 INSULATION

A. General:

- a. Install insulation materials, accessories, and finishes with smooth, straight, and even surfaces; free of voids throughout the length of piping, including fittings, valves, and specialties.
- b. Insulate all lengths of pipe as shown in the Plans.
- c. Install insulation materials, forms, vapor barriers or retarders, jackets, and of thicknesses required for each item of pipe system, as specified in insulation system schedules.
- d. Install accessories compatible with insulation materials and suitable for the service. Install accessories that do not corrode, compress, or otherwise damage insulation or jacket.
- e. Install insulation with longitudinal seams at top and bottom (12 o'clock and 6 o'clock positions) of horizontal runs.
- f. When necessary, install multiple layers of insulation with longitudinal and end seams staggered.
- g. Do not weld brackets, clips, or other attachment devices to piping, fittings, and specialties.
- h. Keep insulation materials dry during storage, application, and finishing. Replace insulation materials that get wet during storage or in the installation process before being properly covered and sealed in accordance with Contract Documents.
- i. Install insulation with tight longitudinal seams and end joints. Bond seams and joints with adhesive recommended by insulation material manufacturer.
- j. Install insulation with least number of joints practical.
- k. Apply adhesives, mastics, and sealants at manufacturer's recommended coverage rate and wet and dry film thicknesses.
- l. Cut insulation in a manner to avoid compressing insulation.
- m. Finish installation with systems at operating conditions. Repair joint separations and cracking due to thermal movement.
- n. Repair damaged insulation facings by applying same facing material over damaged areas. Extend patches at least 4 inches beyond damaged areas. Adhere, staple, and seal patches in similar fashion to butt joints.

3.05 FIELD QUALITY CONTROL

A. Perform the following tests and inspections:

1. Piping Inspections:

- a. Do not enclose, cover, or put piping into operation until it has been inspected and approved by authorities having jurisdiction.
- b. During installation, notify authorities having jurisdiction at least one day before inspection must be made. Perform tests specified below in presence of authorities having jurisdiction:
 - i. Roughing-in Inspection: Arrange for inspection of piping before concealing or closing in after roughing in and before setting fixtures.
 - ii. Final Inspection: Arrange for authorities having jurisdiction to observe tests specified in "Piping Tests" Subparagraph below and to ensure compliance with requirements
- c. Reinspection: If authorities having jurisdiction find that piping will not pass tests or inspections, make required corrections and arrange for reinspection.
- d. Reports: Prepare inspection reports and have them signed by authorities having jurisdiction.

2. Piping Testing:

- a. Fill domestic water piping. Check components to determine that they are not air bound and that piping is full of water.
 - b. Test for leaks and defects in new piping and parts of existing piping that have been altered, extended, or repaired. If testing is performed in segments, submit a separate report for each test, complete with diagram of portion of piping tested.
 - c. Leave new, altered, extended, or replaced domestic water piping uncovered and unconcealed until it has been tested and approved. Expose work that was covered or concealed before it was tested.
 - d. Cap and subject piping to static water pressure of 50 psig (345 kPa) above operating pressure, without exceeding pressure rating of piping system materials. Isolate test source and allow it to stand for four hours. Leaks and loss in test pressure constitute defects that must be repaired.
 - e. Hydrostatic testing and documentation of test results for polypropylene piping to be in accordance with the manufacturer's instructions and submitted to the manufacturer upon successful completion per warranty requirements.
 - f. Repair leaks and defects with new materials, and retest piping or portion thereof until satisfactory results are obtained.
 - g. Prepare reports for tests and for corrective action required.
3. Domestic water piping will be considered defective if it does not pass tests and inspections.
4. Prepare test and inspection reports.

3.06 DISINFECTION AND CLEANING

- A. Clean and disinfect potable water piping as follows:
 - 1. Purge new piping and parts of existing piping that have been altered, extended, or repaired before using
 - 2. Use purging and disinfecting procedures described below:

SECTION 33121

SMALL DIAMETER WATER TIE-INS

PART I – GENERAL

1.01 DESCRIPTION

- A. This section covers small diameter ($\leq 4''$) water tie-ins.

1.02 REFERENCED STANDARDS

- A. SAWS Construction Specification 840 Water Tie-Ins
- B. Section 33120 Small Diameter Pipe and Fittings

PART 2 – PRODUCTS

2.01 GENERAL

- A. Provide materials as specified in 33120 Small Diameter Pipe and Fittings.

PART 3 – EXECUTION

3.01 GENERAL

- A. Perform water tie-ins in accordance with SAWS Construction Specification 840 Water Tie-Ins.

3.02 MEASUREMENT AND PAYMENT

- A. Small diameter tie-ins shall be measured and paid for by each tie in. Payment shall include fittings, transition couplers, pipe, trenching, excavation, backfill, embedment, and all other required appurtenances to perform a small diameter tie-in.

END OF SECTION